



# LEVEL 3 OPTION BOOK 2017

BOTANY DOWNS Secondary College

# CONTENTS

School Contacts	Page 3
Option Information	Page 4
Vocational Pathways	Page 5
BDSC Course Structure	Page 6
Departmental Subject flow charts	Page 7 - 14

## LEVEL 3 OPTIONAL SUBJECTS

Every Year 13 student at Botany Downs Secondary College can choose 5 options. Information for these courses can be found on the following pages listed.

Accounting (ACC3)	Page 15
Art History (ARH3)	Page 16
Biology (BIO3 & BIA3)	Page 17
Business Studies (BUS3)	Page 18
Calculus (MAC3)	Page 19
Calculus - Alternative (MCA3)	Page 20
Career Pathways (CAP3)	Page 21
Chemistry (CHE3)	Page 22
Classical Studies (CLS3)	Page 23
Dance (DAN3)	Page 24
Design and Visual Communication (DVC3)	Page 25
Digital Technologies with Programming (DIP3)	Page 26
Digital Technologies (DIT3)	Page 27
Drama (DRA3)	Page 28
Early Childhood Education (ECE3)	Page 29
Economics (ECO3)	Page 30
Electronics (ELE3)	Page 31
English - Extended (ENE3)	Page 32

English (ENG3)	Page 33
English - Alternative (ENA3)	Page 34
English as an Additional Language (ENS3)	Page 35
Financial Studies (FIN3)	Page 36
Food & Hospitality (FAH3)	Page 37
Food Technology (TEF3)	Page 38
French (FRE3)	Page 39
Geography (GEO3)	Page 40
Health Education (HED3)	Page 41
History (HIS3)	Page 42
Japanese (JAP3)	Page 43
Mathematics (MAT3)	Page 44
Microsoft Office Specialist (MOS3)	Page 45
Multi Material Technology (TEM3)	Page 46
Media Studies (MED3)	Page 47
Music Practical (MUP3)	Page 48
Music Studies (MUS3)	Page 49
Outdoor Education (OED3)	Page 50
Physical Education (PED3)	Page 51
Physics (PHY3)	Page 52
Spanish (SPH3)	Page 53
Sports Leadership (SPL3)	Page 54
Statistics & Probability (SAP3)	Page 55
Statistics & Probability - Alternative (SPA3)	Page 56
Textiles Technology (TET3)	Page 57
Travel and Tourism (TSM3)	Page 58
Visual Art - Design (DES3)	Page 59
Visual Art - Painting (ART3)	Page 60
Visual Art - Photography (PHO3)	Page 61

# SCHOOL CONTACTS



**Botany Downs Secondary College**  
575 Chapel Road, Howick  
Auckland 1706

Phone (09) 273-2310  
Fax (09) 273-8551

Email [admin@bdsc.school.nz](mailto:admin@bdsc.school.nz)

Web Site [www.bdsc.school.nz](http://www.bdsc.school.nz)

## SENIOR LEADERSHIP TEAM

Principal	<i>K. Brinsden</i>
Associate Principal	<i>F. Cottam</i>
Deputy Principal	<i>M. Hart</i>
Deputy Principal	<i>C. Williams</i>
Director of Academic Studies	<i>C. Van Kralingen</i>

## HEADS OF LEARNING AREAS

English	<i>K. Logan</i>
Health and Physical Education	<i>J. Saville</i>
Languages	<i>M. Lodge</i>
Mathematics and Statistics	<i>I. Bennet</i>
Science	<i>L. Kumar</i>
Social Sciences	<i>M. Andrew</i>
Technology	<i>D. Achary</i>
Visual and Performing Arts	<i>J. Hood, L. Treneman, T. Clapperton, A. Rakanui</i>

## WHĀNAU HOUSE LEADERS

Blake Whānau	<i>A. Taylor</i>
Britten Whānau	<i>D. McGregor</i>
Discovery Whānau	<i>N. Folks</i>
Endeavour Whānau	<i>K. Adams</i>
Koru Whānau	<i>C. Joyce (acting for J. Clark)</i>
Spirit Whānau	<i>S. Jackson</i>

## STUDENT SERVICES

Guidance Counsellor	<i>L. Rowe</i>
Careers Advisor	<i>M. Drum</i>
Trade Academies/Vocational Pathways	<i>S. Malone</i>

# OPTION INFORMATION

*The following booklet contains information of the Level 3 programme at BDSC.*

- All following subjects will run depending on the number of applicants and availability of staff and facilities (in practical subjects).
- Entry to some courses will be limited.
- Entry to all courses will be at the discretion of the appropriate Head of Learning Area.
- The final selection of standards for each subject (worth approx 18-24 credits) will be made from the standards presented in this option booklet.
- The column labelled “CODES” contains:
  - R or W which identifies standards that can contribute to the Reading and Writing credits for the University Entrance Literacy requirements.
- NOTE: Can not choose both FAH3 and TEF3  
Can only do 1 max of TEM3, TET3 and TEF3  
Can only do 2 max of PHO3, DES3 and ART3 (and be wary of a 3<sup>rd</sup> high internal subject)  
Can only do 2 max of PED3, SPL3, OED3/ODA3  
Can only do 2 max of DIT3, DIP3 and TEM3/TET3/TEF3  
Can not choose MOS3 with either DIP3 or DIT3

# VOCATIONAL PATHWAYS

Vocational Pathways is a Ministry of Education tool that has been developed to help students to plan their journey from secondary learning to the work force. Additional information about Vocational Pathways is available in the Level 1 - 3 information book.

The pathways will help students see how learning is relevant to a wide range of jobs and study options, in six broad sectors of industry:

- Construction and Infrastructure Sector
- Manufacturing and Technology Sector
- Primary Industries Sector
- Services Industries Sector
- Social and Community Services Sector and
- Creative Industries Sector.



On each option page there is a coloured ticked section indicating which standards relate to which industry sector.

For example Level 3 Spanish:

The achievement standard “AS91570 Interact clearly using spoken Spanish to explore and justify varied ideas and perspectives in different situations ” has links to Service Industries, Social & Community Services and Creative Industries. This gives the student an idea of the real-world application of the knowledge learnt during this standard. What’s my Pathway?

STANDARDS							VOCATIONAL PATHWAYS					
Number	Subject Ref	Title	Int/Ext	Credits	CODES	Construction & Infrastructure	Manufacturing & Technology	Primary Industries	Service Industries	Social & Community Services	Creative Industries	
<i>NCEA Internal Achievement Standards/Unit Standards</i>												
AS91570	Spanish 3.3	Interact clearly using spoken Spanish to explore and justify varied ideas and perspectives in different situations	Int	6					✓	✓	✓	
AS91572	Spanish 3.5	Write a variety of text types in clear Spanish to explore and justify varied ideas and perspectives.	Int	5					✓			
AS91569	Spanish 3.2	Give a clear spoken presentation in Spanish that communicates a critical response to stimulus material.	Int	3								
<i>NCEA External Achievement Standards</i>												
AS91568	Spanish 3.1	Demonstrate understanding of a variety of extended spoken Spanish texts.	Ext	5					✓			
AS91571	Spanish 3.4	Demonstrate understanding of a variety of extended written/visual Spanish texts.	Ext	5								
				<i>Possible Credits Available</i>		24 Credits						

# BDSC COURSE STRUCTURE 2017

Compulsory Subjects *Italic*. Optional Subjects Normal.

Learning Areas	Year 9	Year 10	Level 1	Level 2	Level 3
<b>English</b>	<i>English (9ENG)</i> English Literacy Support (9ENA)	<i>English (10ENG)</i> English Literacy Support (10ENA)	<i>English (ENG1)</i> <i>English - Alternative (ENA1)</i>	<i>English (ENG2)</i> <i>English - Alternative (ENA2)</i>	English - Extended (ENE3) English (ENG3) English - Alternative (ENA3) Media Studies (MED3)
	English as an Add. Lang. (9ENS)	English as an Add. Lang. (10ENS) English as an Add. Lang. (10ENP)	<i>English as an Add. Lang. (ENS1)</i> <i>English as an Add. Lang. (ENP1)</i>	<i>English as an Add. Lang. (ENS2)</i> <i>English as an Add. Lang. (ENP2)</i>	English as an Add. Lang. (ENS3)
<b>Health &amp; Physical Education</b>	<i>Health &amp; PE (9HPE)</i>	<i>Health &amp; PE (10HPE)</i>	<i>Health &amp; PE (HPE1)</i>	Early Childhood Education (ECE2) Health Education (HED2) Outdoor Education (OED2) Outdoor Education - Alternative (ODA2) Physical Education (PED2) Sports Leadership (SPL2)	Early Childhood Education (ECE3) Health Education (HED3) Outdoor Education (OED3) Physical Education (PED3) Sports Leadership (SPL3)
		Outdoor Leadership (10ODL) Physical Education (10PED)	Early Childhood Education (ECE1) Health Education (HED1) Outdoor Education (OED1) Physical Education (PED1)		
<b>Languages</b>	<i>French (9FRE)</i> <i>Japanese (9JAP)</i>	French (10FRE) Japanese (10JAP) Maori (10MAO) Spanish (10SPH)	French (FRE1) Japanese (JAP1) Maori (MAO1) Spanish (SPH1)	French (FRE2) Japanese (JAP2) Spanish (SPH2)	French (FRE3) Japanese (JAP3) Spanish (SPH3)
<b>Mathematics</b>	<i>Mathematics and Statistics (9MAT)</i>	<i>Maths. and Stats. (10MAT)</i> <i>Maths. and Stats. - Alternative (10MAA)</i> <i>Maths. and Stats. - Accelerated (MAX1)</i>	<i>Maths. and Stats. - Numeracy (MNU1)</i> <i>Maths. and Stats. - Alternative (MAA1)</i> <i>Maths. and Stats. (MAT1, MAE1)</i> <i>Maths. and Stats. - Accelerated (MAX2)</i>	Maths. and Statistics - Alternative (MAA2) Maths. and Statistics (MAT2) Maths. and Statistics - Extended (MAE2) Calculus - Accelerated (MAX3)	Calculus (MAC3) Calculus - Alternative (MCA3) Statistics and Prob. (SAP3) Statistics and Prob. - Alternative (SPA3) Mathematics (MAT3)
<b>Science</b>	<i>Science (9SCI)</i>	<i>Science (10SCI)</i> <i>Science - Accelerated (10SCX1)</i>	<i>Science (SC11)</i> <i>Science - Alternative (SCA1)</i> Supplementary Science (SCS1)	Biology (BIA2, BIO2) Chemistry (CHE2) Electronics (ELE2) Physics (PHY2)	Biology (BIA3, BIO3) Chemistry (CHE3) Electronics (ELE3) Physics (PHY3)
		Electronics (10ELE)	Electronics (ELE1)		
<b>Social Sciences</b>	<i>Social Studies (9SOS)</i>	<i>Social Studies (10SOS)</i>	Accounting (ACC1) Business Studies (BUS1) Economics (ECO1) Geography (GEO1) History (HIS1)	Accounting (ACC2) Business Studies (BUS2) Classical Studies (CLS2) Economics (ECO2) Financial Studies (FIN2) Geography (GEO2) History (HIS2) Travel and Tourism (TSM2)	Accounting (ACC3) Business Studies (BUS3) Classical Studies (CLS3) Economics (ECO3) Financial Studies (FIN3) Geography (GEO3) History (HIS3) Travel and Tourism (TSM3)
		Ancient Civilisations (10ANC) Business Pathways (10BUP) Investigative Geography (10IGO)			
<b>Technology</b>	<i>Design and Visual Com. (9DVC)</i> <i>Food Technology (9TEF)</i> <i>Multi Materials Technology (9TEM)</i> <i>Textiles Technology (9TET)</i>	Design and Visual Com. (10DVC) Digital Technology (10DIT) Food Technology (10TEF) Multi Materials Technology (10TEM) Textiles Technology (10TET)	Digital Technologies (DIT1) Design and Visual Com. (DVC1) Food and Hospitality (FAH1) Food Technology (TEF1) Multi Materials Technology (TEM1) Textiles Technology (TET1)	Automotive Engineering (ATM2) Building Construction (BCN2) Digital Technologies with Programming (DIP2) Digital Technologies (DIT2) Design and Visual Com. (DVC2) Food and Hospitality (FAH2) Food Technology (TEF2) Microsoft Office Specialist (MOS2) Multi Materials Technology (TEM2) Textiles Technology (TET2)	Digital Technologies with Programming (DIP3) Digital Technologies (DIT3) Design and Visual Com. (DVC3) Food and Hospitality (FAH3) Food Technology (TEF3) Microsoft Office Specialist (MOS3) Multi Materials Technology (TEM3) Textiles Technology (TET3)
<b>The Arts</b>	<i>Dance (9DAN)</i> <i>Drama (9DRA)</i> <i>Music (9MUS)</i> <i>Visual Art (9ART)</i>	Dance (10DAN) Digital Art (10DRT) Drama (10DRA) Music (10MUS) Visual Art (10ART)	Dance (DAN1) Digital Art (DRT1) Drama (DRA1) Music (MUS1) Visual Art (ART1)	Dance (DAN2) Drama (DRA2) Music (MUS2) Visual Art (ART2) Art History (ARH2) Design (DES2) Photography (PHO2)	Dance (DAN3) Drama (DRA3) Music Practical (MUP3) Music Studies (MUS3) Visual Art (ART3) Art History (ARH3) Design (DES3) Photography (PHO3)
<b>Vocational &amp; General Courses</b>			Work and Community Studies (WCS1)	Career Pathways (CAP2)	Career Pathways (CAP3)



# ENGLISH FLOWCHART 2017

Key:

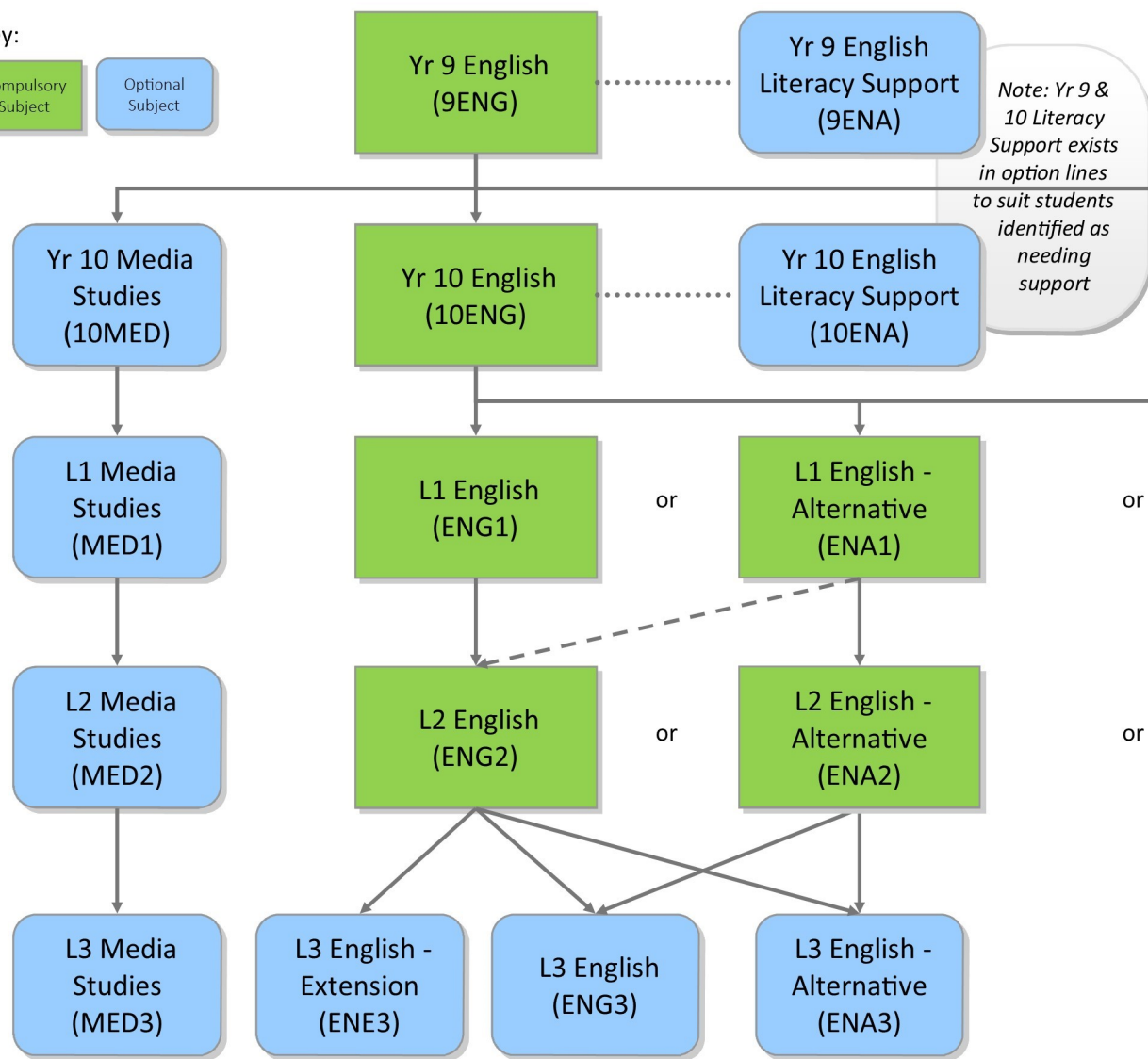

*Note: Yr 9 & 10 Literacy Support exists in option lines to suit students identified as needing support*

# ENGLISH AS ADDITIONAL LANGUAGE (EAL) FLOWCHART 2017

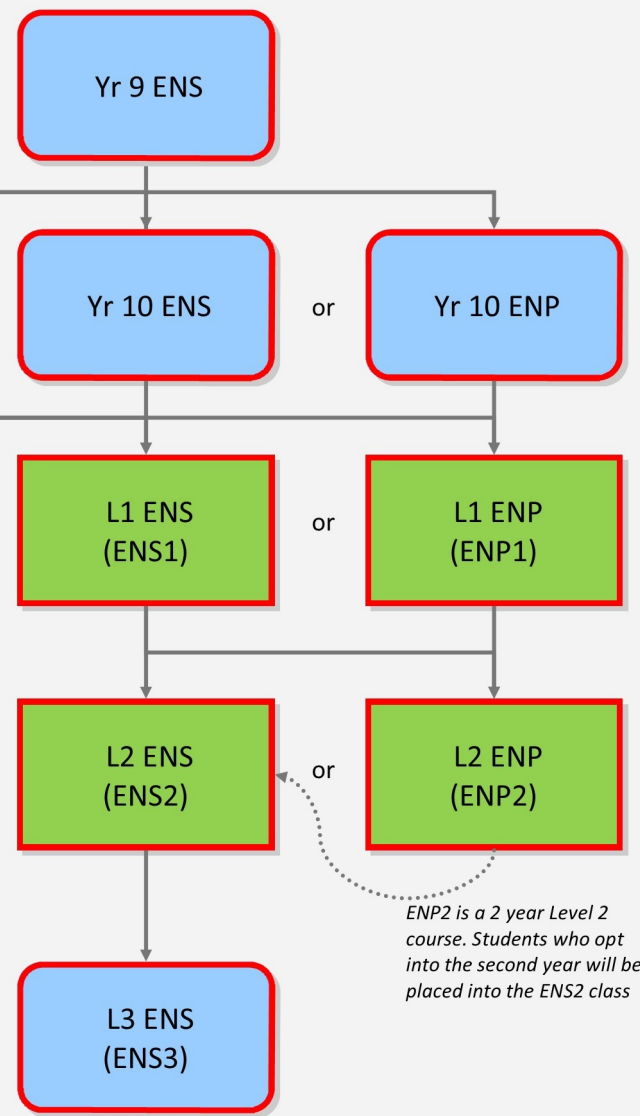

*ENP2 is a 2 year Level 2 course. Students who opt into the second year will be placed into the ENS2 class*

## ENGLISH AS AN ADDITIONAL LANGUAGE

At Year 9 and 10 identified students may be removed from a Year 9 class or a Year 10 option line to attend 9ENS or 10ENS/10ENP class to support their language development.  
 At Year 11/12/13 identified students may be placed in ENS or ENP instead of ENG, dependant on the Head of EAL recommendation. Students may be swapped between ENS and ENP depending on the level of English.

# HEALTH & PHYSICAL EDUCATION FLOWCHART 2017

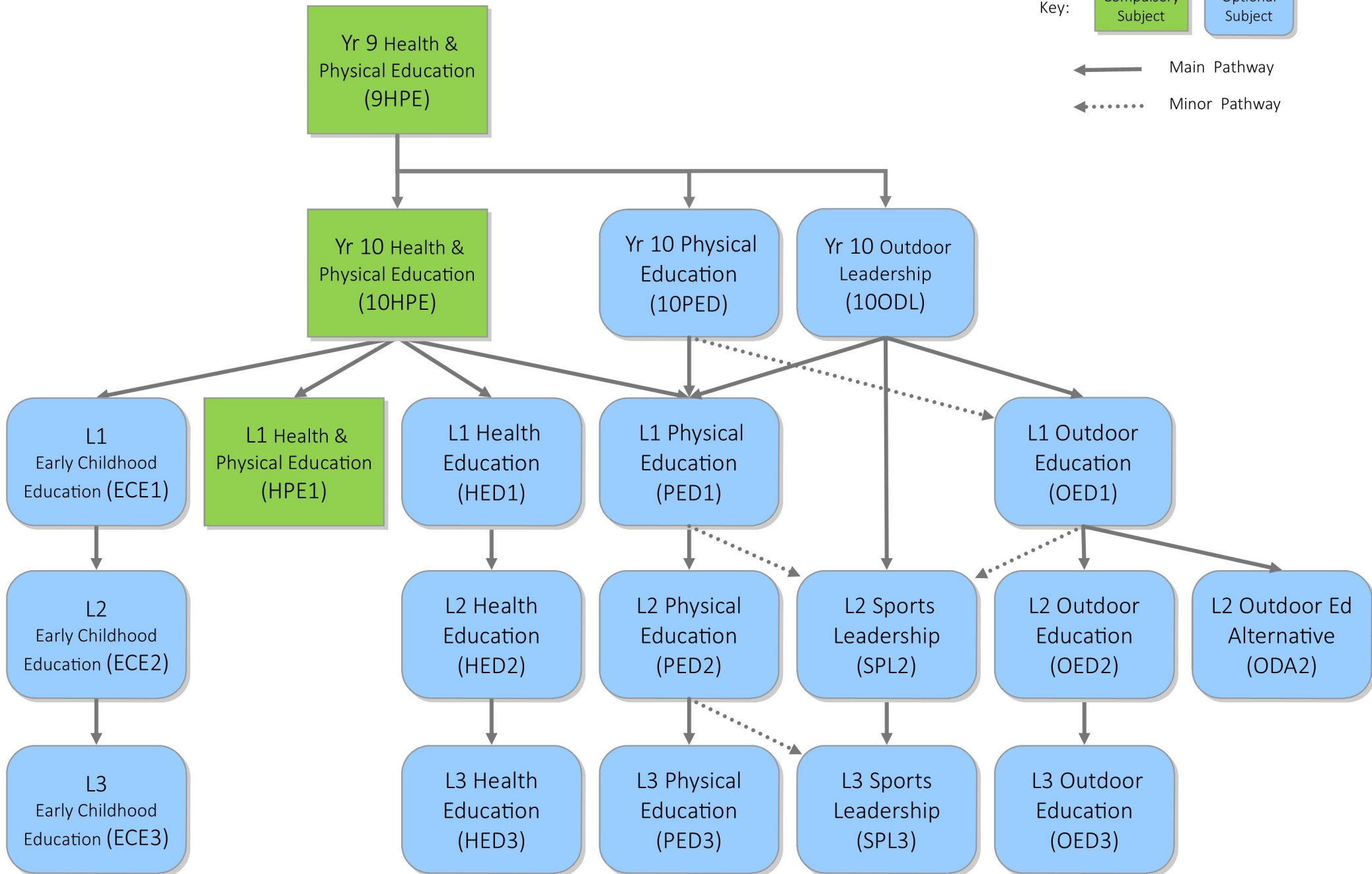
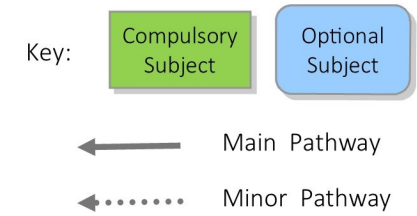



# LANGUAGES FLOWCHART 2017

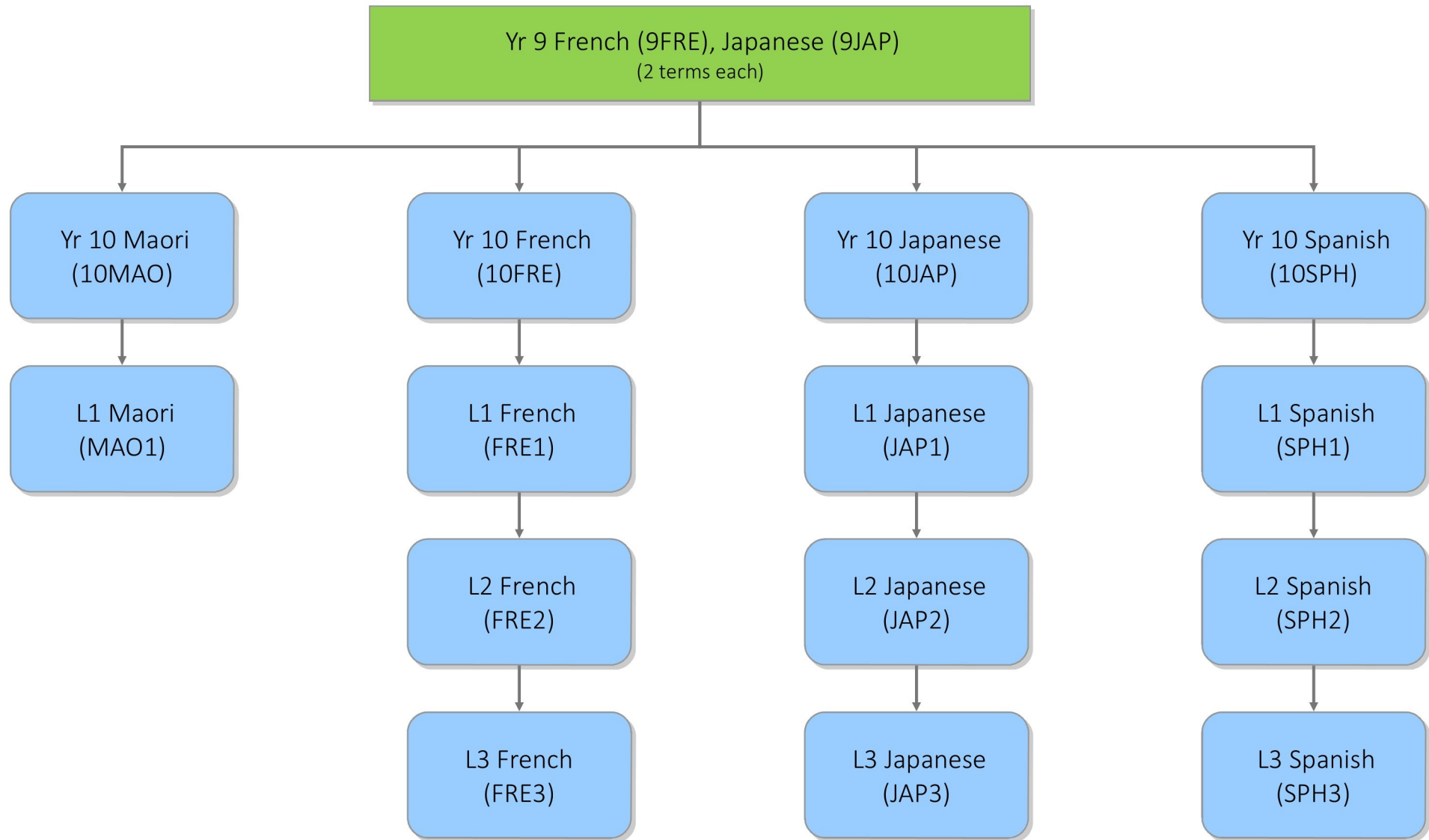

# MATHEMATICS & STATISTICS - SUBJECT FLOWCHART 2017

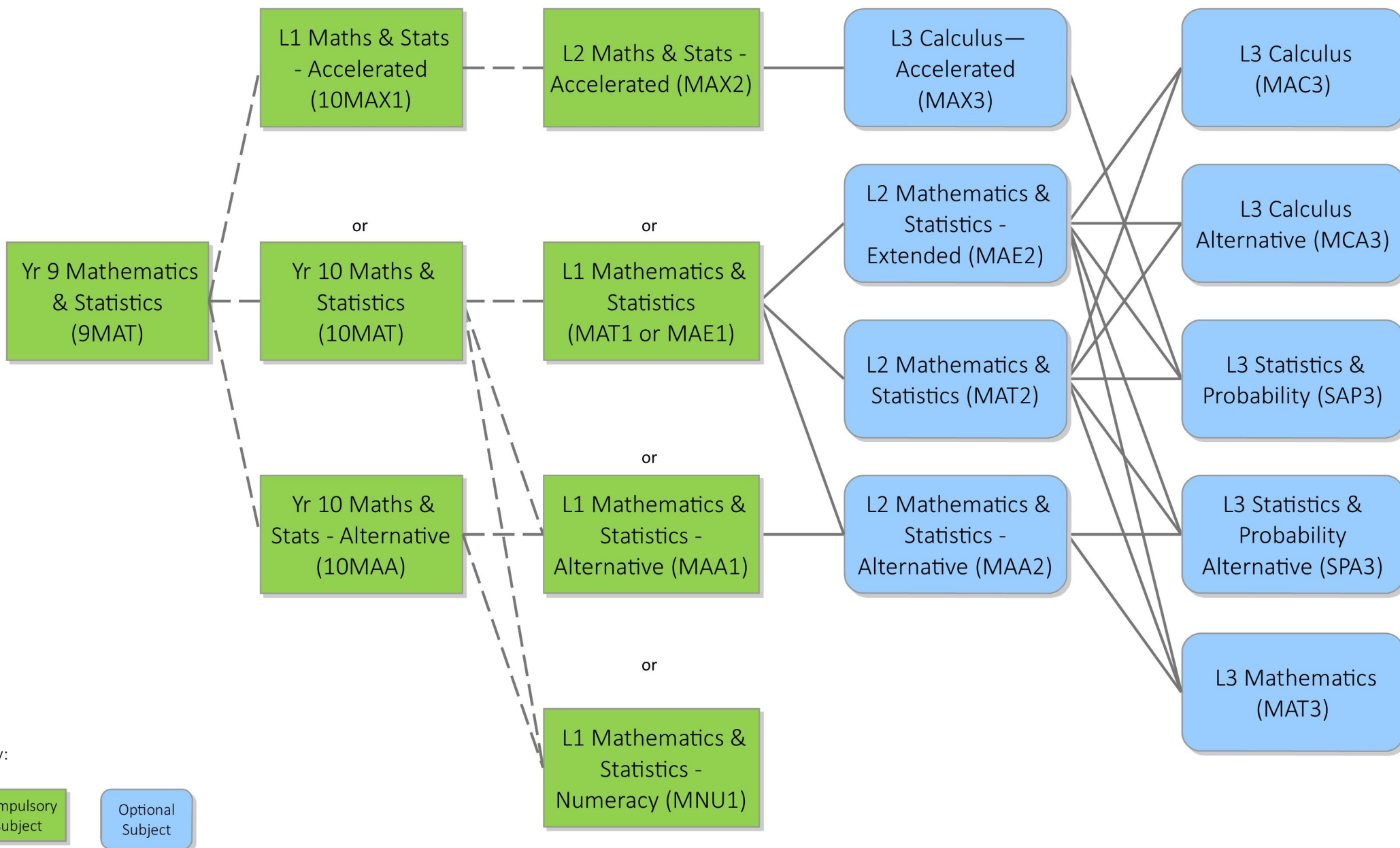

Key:

Compulsory Subject

Optional Subject

Key: Dashed lines refer to courses which are selected for the students by Mathematics staff

# SCIENCE - SUBJECT FLOWCHART 2017

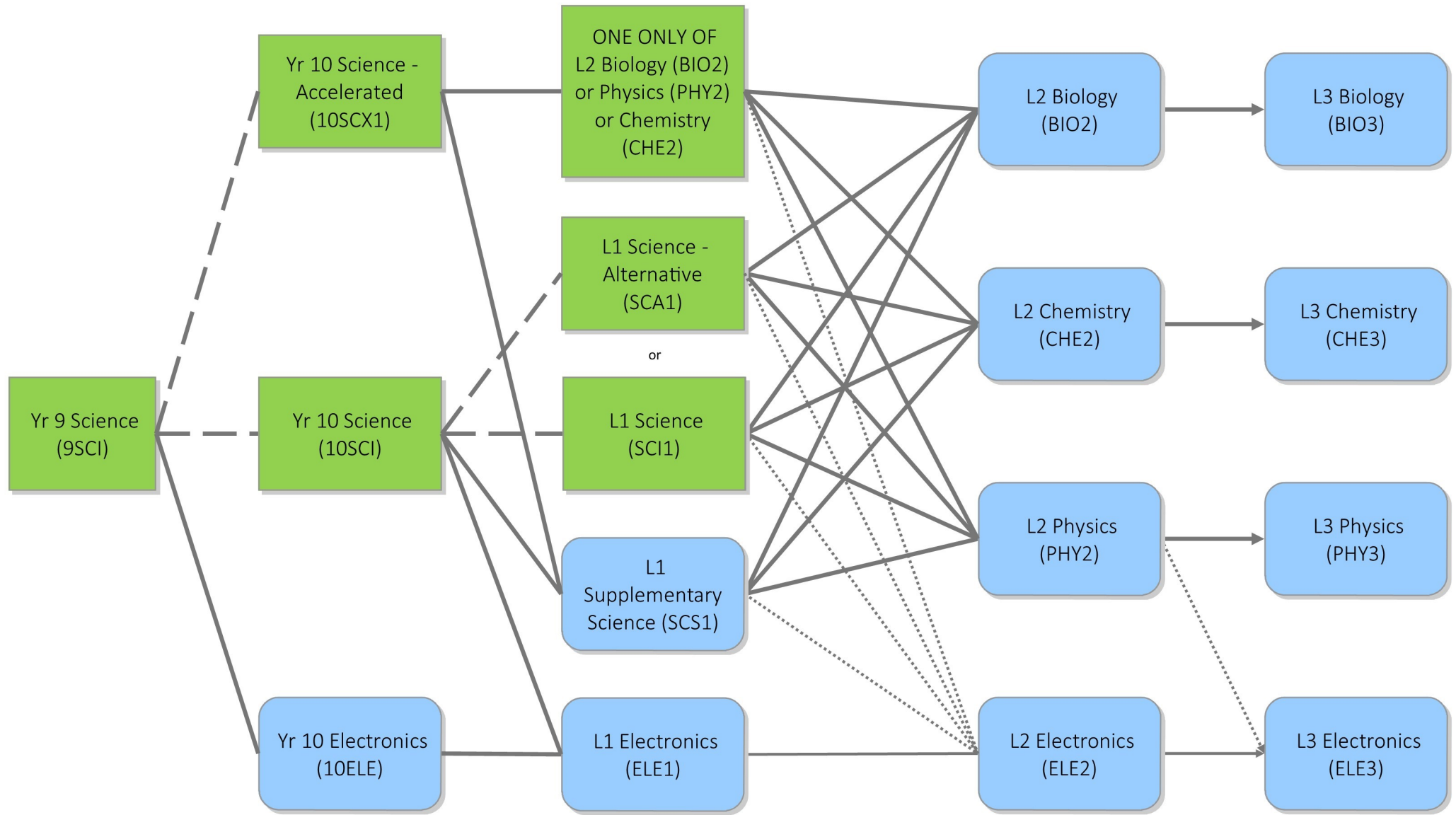

- Key:
- Compulsory Subject
  - Optional Subject
  - Main Pathway
  - Other Pathway
  - refer to a course which is selected for the students by Science staff

# SOCIAL SCIENCES - SUBJECT FLOWCHART 2017

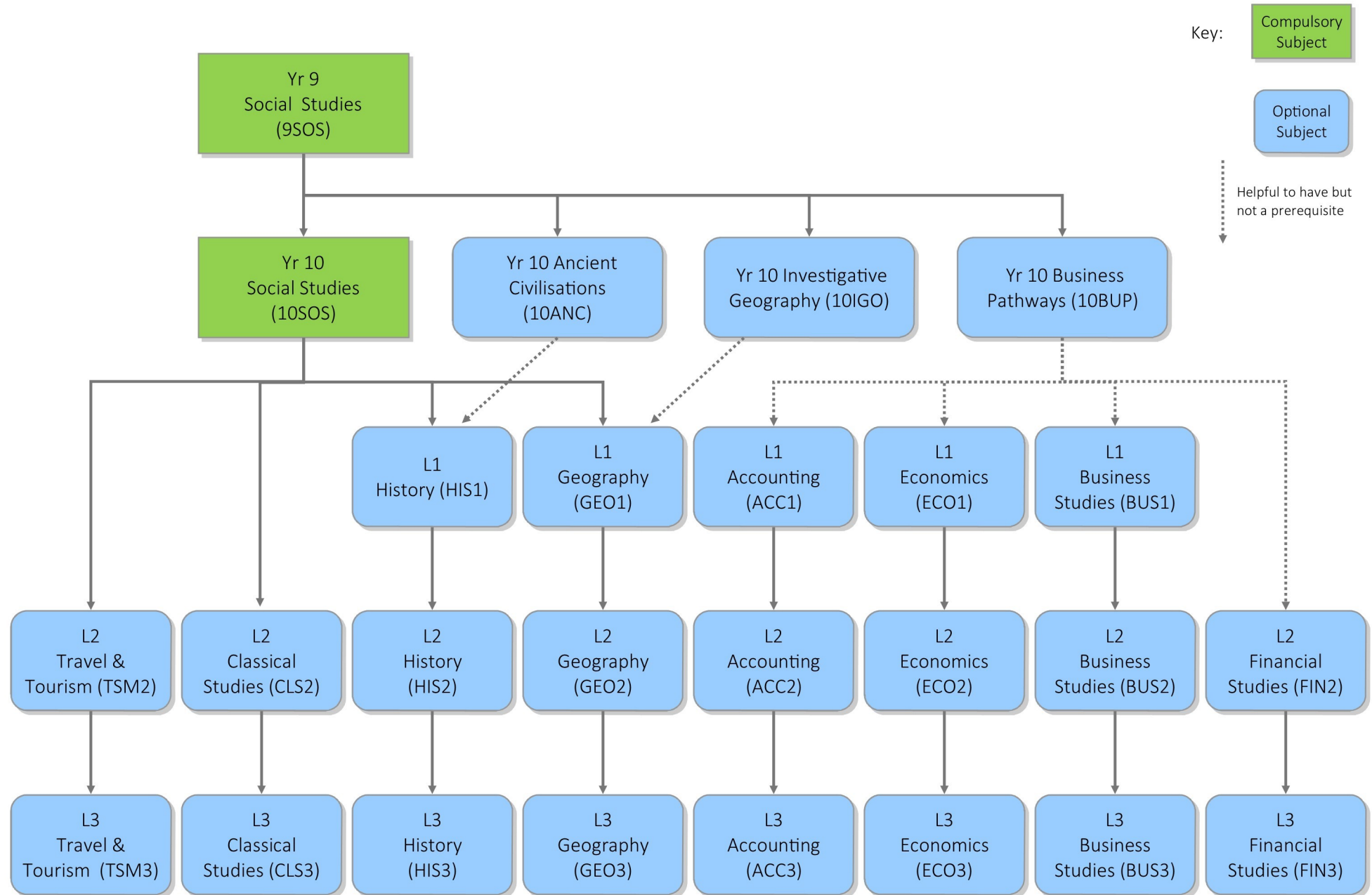

# TECHNOLOGY - SUBJECT FLOWCHART 2017

Yr 9 Food (9TEF), Textiles (9TET), Design & Visual Communication (9DVC),  
Multi Materials (9TEM) (1 term each)

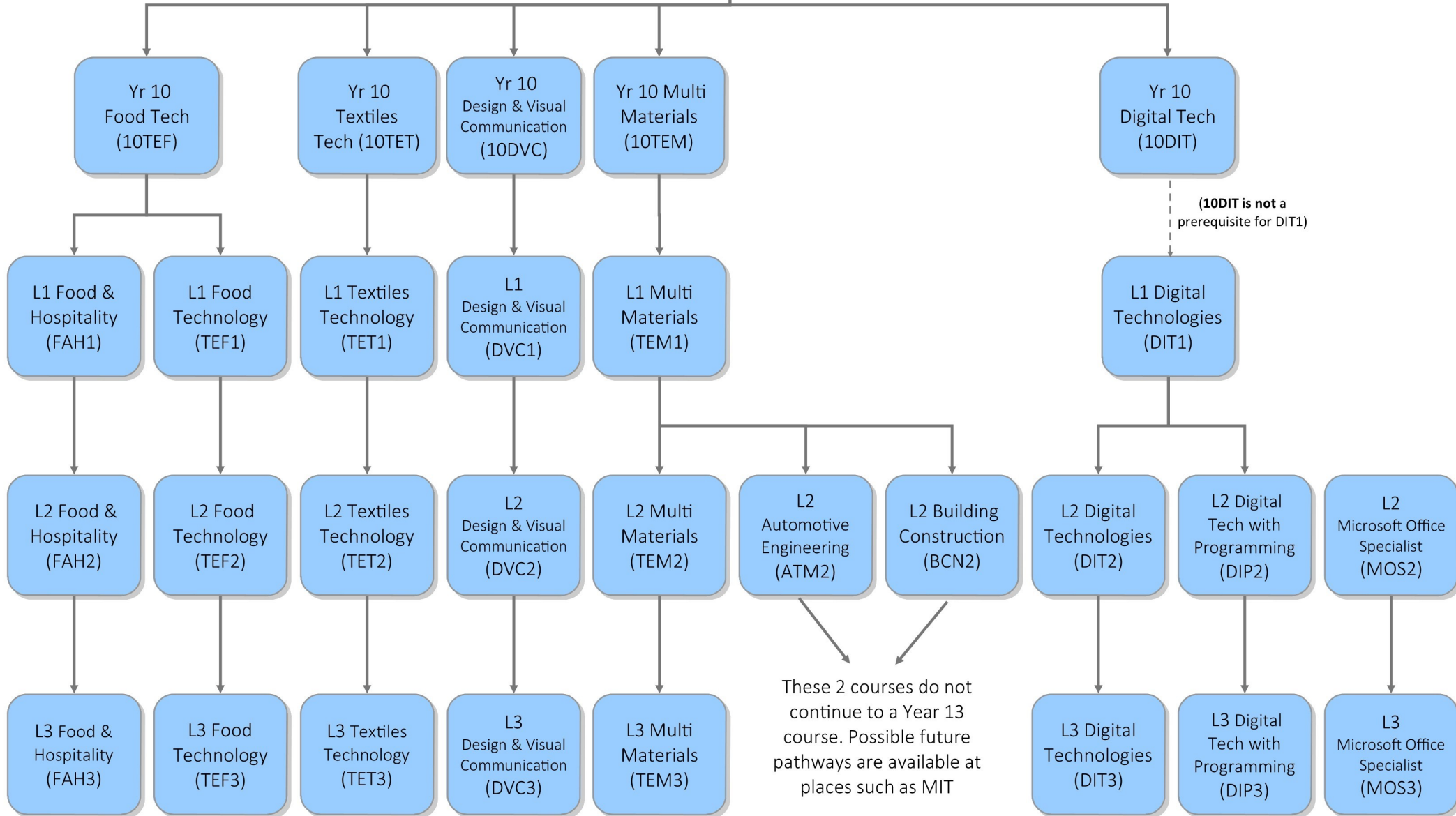



# VISUAL & PERFORMING ARTS - SUBJECT FLOWCHART 2017

Yr 9 Dance (9DAN), Drama (9DRA), Music (9MUS), Visual Art (9ART)  
(1 term each)

With portfolio application  
and HOLA approval  
.....→

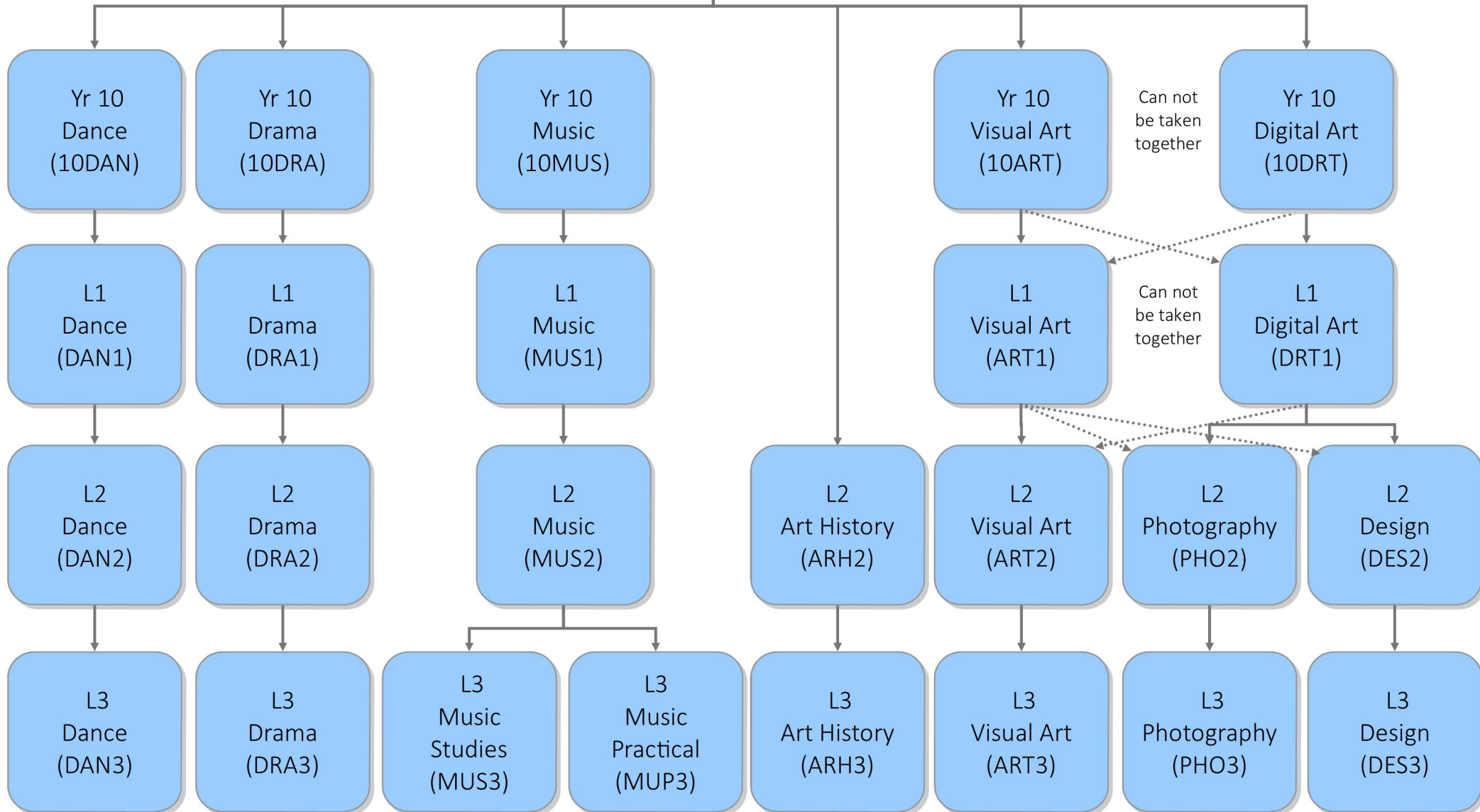

# ACCOUNTING (ACC3)

## COURSE INFORMATION

Qualification and level:	NCEA Level 3
Course Prerequisites:	12 credits in NCEA Level 2 Accounting
Fieldwork:	Nil
Approximate Course Costs:	Approximately \$60 for workbook and fee Approximately \$40 for trips
Course Leads to:	Tertiary Study and careers in Auditing, Budget Analysis, Financial or Management Accounting and Tax Accounting for Accounting Firms, Government, Corporations or even running your own Accounting firm.
Course Provider/Assessor:	Botany Downs Secondary College
Teacher in charge of subject:	Mrs McArthur
HOLA in charge of subject:	Mr Andrew

## COURSE OUTLINE

The purpose of Accounting is to provide financial and non-financial information to assist decision-making in the management of, and investment in, public and private sector organisations. The major roles of an accountant are to identify, measure, interpret and communicate information relevant to these decisions. In addition, the study of Accounting is designed to promote critical thinking and develop practical competencies, and prepare students for university education and a wide variety of careers. This course builds on the introductory Accounting studied at Level 1 and 2, and moves it into the sphere of partnerships and companies. Concepts are applied to these businesses; processing undertaken and statements are provided.

**This is a NCEA Level 3 approved subject.**

## STANDARDS

Standards for this course will be selected from those listed below and are at the discretion of the HOLA  
Level 2 Standards that contribute to Literacy and Numeracy are indicated by (L) = Literacy; (N) = Numeracy  
Level 2 & 3 Standards that contribute to UE literacy requirements are indicated by (R) = Reading; (W) = Writing

## VOCATIONAL PATHWAYS

Vocational Pathway information helps with future career planning. Each Standard has been aligned to a potential Pathway, reflected by a tick in the relevant column of the table. "What is your pathway?" Please refer to page 5 in this book or pages 22 and 23 in the Level 1-3 Information Book for more information regarding Vocational Pathways.

STANDARDS							VOCATIONAL PATHWAYS					
Number	Subject Ref	Title	Int/Ext	Credits	CODES	Construction & Infrastructure	Manufacturing & Technology	Primary Industries	Service Industries	Social & Community Services	Creative Industries	
<i>NCEA Internal Achievement Standards/Unit Standards</i>												
AS91407	Accounting 3.4	Prepare a report for an external user that interprets the annual report of a New Zealand reporting entity.	Internal	5	R/W							
AS91409	Accounting 3.6	Demonstrate understanding of a job cost subsystem for an entity.	Internal	4								
<i>NCEA External Achievement Standards</i>												
AS91406	Accounting 3.3	Demonstrate understanding of company financial statement preparation.	External	5					✓			
AS91408	Accounting 3.5	Demonstrate understanding of management accounting to make a decision.	External	4				✓	✓			
<i>Possible Credits Available</i>				18 Credits								

# ART HISTORY (ARH3)

## COURSE INFORMATION

Qualification and level:	NCEA Level 3
Course Prerequisites:	12 credits in NCEA Level 2 Art History or 12 Level 2 Literacy credits or at HOLA discretion.
Fieldwork:	Trips to Auckland Art Gallery and/or museum and/or Art History Department at Auckland University.
Approximate Course Costs:	Approximately \$40 for two trips and \$60 for course workbooks.
Course Leads to:	Tertiary Study in Fine Arts/Art History
Course Provider/Assessor:	Botany Downs Secondary College
Teacher in charge of subject:	Miss Henshaw
HOLA in charge of subject:	Miss Clapperton

## COURSE OUTLINE

This is an academic course, which focuses on written responses to art works and their historical contexts. Students study contemporary Western art forms from 20th Century Europe. They are required to research, analyse and respond to given artworks and artists and students learn terminology and language specific to the visual arts. This course prepares students for tertiary study in the arts and complements the Level 3 practical art courses and Classics.

It is recommended that students choosing to take this course have access to their own digital device to use for research, as this forms a large component of the three internal assessments.

**This is a NCEA Level 3 approved subject.**

## STANDARDS

Standards for this course will be selected from those listed below and are at the discretion of the HOLA  
 Level 2 Standards that contribute to Literacy and Numeracy are indicated by (L) = Literacy; (N) = Numeracy  
 Level 2 & 3 Standards that contribute to UE literacy requirements are indicated by (R) = Reading; (W) = Writing

## VOCATIONAL PATHWAYS

Vocational Pathway information helps with future career planning. Each Standard has been aligned to a potential Pathway, reflected by a tick in the relevant column of the table. "What is your pathway?" Please refer to page 5 in this book or pages 22 and 23 in the Level 1-3 Information Book for more information regarding Vocational Pathways.

STANDARDS							VOCATIONAL PATHWAYS					
Number	Subject Ref	Title	Int/Ext	Credits	CODES	Construction & Infrastructure	Manufacturing & Technology	Primary Industries	Service Industries	Social & Community Services	Creative Industries	
<i>NCEA Internal Achievement Standards/Unit Standards</i>												
AS91485	Art His 3.4	Examine the impact of media and processes on art works	Internal	4	R				✓		✓	
AS91486	Art His 3.5	Construct an argument based on interpretation of research in art history	Internal	4	R						✓	
AS91487	Art His 3.6	Examine the different values placed on art works	Internal	4	R						✓	
<i>NCEA External Achievement Standards</i>												
AS91482	Art His 3.1	Demonstrate understanding of style in art works	External	4	R/W						✓	
AS91483	Art His 3.2	Examine how meanings are communicated through art works	External	4	R/W				✓		✓	
AS91484	Art His 3.3	Examine the relationship (s) between art and context	External	4	R/W						✓	
<i>Possible Credits Available</i>				24 Credits								

# BIOLOGY (BIO3/BIA3)

## COURSE INFORMATION

Qualification and level:	NCEA Level 3
Course Prerequisites:	14 credits in NCEA Level 2 Biology including AS 91157 or AS91159 and 12 credits (NCEA Level 2 Achievement Standards) in both Mathematics and English Students that do not meet the above prerequisites but who still wish to study Biology at NCEA Level 3 can enter into a modified Level 3 course (BIA3). Entry into this course will require the HOD's endorsement.
Fieldwork:	EOTC will be carried out at the Auckland Zoo.
Approximate Course Costs:	\$20.00 (Education perfect online resources)
Course Leads to:	Tertiary Study in Biology or related fields
Course Provider/Assessor:	Botany Downs Secondary College
Teacher in charge of subject:	Mrs Merchant
HOLA in charge of subject:	Mr Kumar

## COURSE OUTLINE

Level 3 Biology continues the themes of Level 2, focusing understanding of genetic change towards speciation, and Human evolution. In addition students are introduced to the behaviours and responses of both plants and animals which allow species continuation and change. Human Biology returns with the study of system responses to the changes in an external environment. In addition to the development of sound knowledge of 21st century biological discoveries, students are also actively encouraged through teaching and assessment to develop research and reporting skills transferable to many other disciplines. Outstanding students may choose to sit the Biology Scholarship (Level 4) exam at the end of the course.

**This is a NCEA Level 3 approved subject.**

## STANDARDS

Standards for this course will be selected from those listed below and are at the discretion of the HOLA  
Level 2 Standards that contribute to Literacy and Numeracy are indicated by (L) = Literacy; (N) = Numeracy  
Level 2 & 3 Standards that contribute to UE literacy requirements are indicated by (R) = Reading; (W) = Writing

## VOCATIONAL PATHWAYS

Vocational Pathway information helps with future career planning. Each Standard has been aligned to a potential Pathway, reflected by a tick in the relevant column of the table. "What is your pathway?" Please refer to page 5 in this book or pages 22 and 23 in the Level 1-3 Information Book for more information regarding Vocational Pathways.

STANDARDS						VOCATIONAL PATHWAYS					
Number	Subject Ref	Title	Int/Ext	Credits	CODES	Construction & Infrastructure	Manufacturing & Technology	Primary Industries	Service Industries	Social & Community Services	Creative Industries
<i>NCEA Internal Achievement Standards/Unit Standards</i>											
AS91602	Biology 3.2	Integrate biological knowledge to develop an informed response to a socio-scientific issue.	Internal	3	R/W			✓		✓	
AS91604	Biology 3.4	Demonstrate understanding of an animal maintains a stable internal environment.	Internal	3	R			✓		✓	
<i>NCEA External Achievement Standards</i>											
AS91603	Biology 3.3	Demonstrate understanding of the responses of plants and animals to their external environment.	External	5	R/W			✓			
AS91605	Biology 3.5	Demonstrate understanding of evolutionary processes leading to speciation.	External	4	R/W			✓		✓	
AS91606	Biology 3.6	Demonstrate understanding of trends in human evolution.	External	4	R/W			✓			
<i>Possible Credits Available</i>				19 credits							

# BUSINESS STUDIES (BUS3)

## COURSE INFORMATION

Qualification and level:	NCEA Level 3
Course Prerequisites:	12 credits (including one external) in NCEA Level 2 Business Studies or at the discretion of HOD Commerce.
Fieldwork:	Students will work with a business to develop an innovative product by assisting them to develop it.
Approximate Course Costs:	\$60 for EOTC + \$35 YES Registration
Course Leads to:	All students who take Business Studies potentially gain the knowledge, skills, and attributes required to become entrepreneurs, run their own business. Some students may pursue further qualifications in Business Studies or commerce at polytechnics, wānanga, or universities.
Course Provider/Assessor:	Botany Downs Secondary College
Teacher in charge of subject:	Mr Sharma
HOLA in charge of subject:	Mr Andrew

## COURSE OUTLINE

The study of business is about how individuals and groups of people organise, plan, and act to create and develop goods and services to satisfy customers. Business is influenced by and impacts on the cultural, ethical, environmental, political, and economic conditions of the day. Issues such as sustainability, citizenship, enterprise, and are central to both business and the study of business.

The knowledge and skills gained in business studies, and exposure to enterprise culture, can help shape “creative, energetic, and enterprising” young people who will contribute to New Zealand’s economic future.

In Level 3 Business Studies, students develop their understanding of business theory and practices in a range of relevant contexts, through experiential as well as theoretical approaches to learning.

Students will gain knowledge, skills, and experience to :

- Analyse how and why businesses in New Zealand operating in the national and global markets make operational and strategic decisions in response to interacting internal and external factors.
- Plan, investigate a product with an export potential and link it to a business marketing plan.
- Students will plan and carry out their own business.

**This is a NCEA Level 3 approved subject.**

## STANDARDS

Standards for this course will be selected from those listed below and are at the discretion of the HOLA  
 Level 2 Standards that contribute to Literacy and Numeracy are indicated by (L) = Literacy: (N) = Numeracy  
 Level 2 & 3 Standards that contribute to UE literacy requirements are indicated by (R) = Reading: (W) = Writing

## VOCATIONAL PATHWAYS

Vocational Pathway information helps with future career planning. Each Standard has been aligned to a potential Pathway, reflected by a tick in the relevant column of the table. “What is your pathway?” Please refer to page 5 in this book or pages 22 and 23 in the Level 1-3 Information Book for more information regarding Vocational Pathways.

STANDARDS							VOCATIONAL PATHWAYS					
Number	Subject Ref	Title	Int/Ext	Credits	CODES	Construction & Infrastructure	Manufacturing & Technology	Primary Industries	Service Industries	Social & Community Services	Creative Industries	
<i>NCEA Internal Achievement Standards/Unit Standards</i>												
AS91382	3.4	Develop a marketing plan for a new or existing product	Internal	6	R			✓	✓		✓	
AS91384	3.6	Carry out, with consultation, an innovative and sustainable business activity	Internal	9	R		✓	✓	✓		✓	
<i>NCEA External Achievement Standards</i>												
AS91379	3.1	Demonstrate an understanding of how internal factors interact within a business that operates in a global context	External	4	R/W			✓	✓			
AS91380	3.2	Demonstrate an understanding of strategic response to external factors by a business that operates in a global context	External	4	R/W			✓	✓			
<i>Possible Credits Available</i>				23 Credits								



# CALCULUS (MAC3)

## COURSE INFORMATION

Qualification and level:	NCEA Level 3
Course Prerequisites:	Merit or better in AS 2.6 - Algebra , AS 2.7 - Calculus and Merit or better in AS 2.4 Trigonometry or AS 2.2 Graphs.
Fieldwork:	Nil
Approximate Course Costs:	Workbook \$35, FX9750GII Casio Graphic calculator -approximately \$120 is compulsory Scholarship workbook – approximately \$25
Course Leads to:	This course will lead to University courses in engineering, sciences and any field where mathematical analysis is important.
Course Provider/Assessor:	Botany Downs Secondary College
Teacher in charge of subject:	Mr Lin
HOLA in charge of subject:	Ms Bennet

## COURSE OUTLINE

Level 3 Calculus will assess all five Calculus Level 3 Achievement Standards giving a total of 27 credits. The aims of the standards are to consolidate and extend students' ability in algebraic, graphical and computations skills, to extend students' ability to formulate problems in mathematical terms and advance students' understanding of the nature of mathematical reasoning. This highly academic course also enables students to work towards scholarship level.

**This is a NCEA Level 3 approved subject.**

## STANDARDS

Standards for this course will be selected from those listed below and are at the discretion of the HOLA  
 Level 2 Standards that contribute to Literacy and Numeracy are indicated by (L) = Literacy; (N) = Numeracy  
 Level 2 & 3 Standards that contribute to UE literacy requirements are indicated by (R) = Reading; (W) = Writing

## VOCATIONAL PATHWAYS

Vocational Pathway information helps with future career planning. Each Standard has been aligned to a potential Pathway, reflected by a tick in the relevant column of the table. "What is your pathway?" Please refer to page 5 in this book or pages 22 and 23 in the Level 1-3 Information Book for more information regarding Vocational Pathways.

STANDARDS						VOCATIONAL PATHWAYS					
Number	Subject Ref	Title	Int/Ext	Credits	CODES	Construction & Infrastructure	Manufacturing & Technology	Primary Industries	Service Industries	Social & Community Services	Creative Industries
<i>NCEA Internal Achievement Standards/Unit Standards</i>											
AS91587	Mathematics 3.15	Apply systems of simultaneous equations in solving problems	Internal	3		✓	✓	✓			
AS91575	Mathematics 3.3	Apply trigonometric methods in solving problems	Internal	4		✓	✓				
AS91574	Mathematics 3.2	Apply linear programming methods in solving problems	Internal	3		✓	✓	✓			
<i>NCEA External Achievement Standards</i>											
AS91577	Mathematics 3.5	Apply the algebra of complex numbers in solving problems	External	5							
AS91578	Mathematics 3.6	Apply differentiation methods in solving problems	External	6		✓	✓	✓		✓	
AS91579	Mathematics 3.7	Apply integration methods in solving problems	External	6		✓	✓	✓			
<i>Possible Credits Available</i>			27 Credits								

# CALCULUS ALTERNATIVE (MCA3)

## COURSE INFORMATION

Qualification and level:	NCEA Level 3
Course Prerequisites:	Must have at least an achievement or better in AS 2.6 - Algebra , AS 2.7 - Calculus and one of AS 2.4 Trigonometry or AS 2.2 Graphs.
Fieldwork:	Nil
Approximate Course Costs:	Workbook \$35, FX9750GII Casio Graphic calculator -approximately \$120 is compulsory
Course Leads to:	This course will lead to University courses in engineering, sciences and any field where mathematical analysis is important.
Course Provider/Assessor:	Botany Downs Secondary College
Teacher in charge of subject:	Mr Lin
HOLA in charge of subject:	Ms Bennet

## COURSE OUTLINE

Level 3 Calculus-Alternative will assess four Calculus Level 3 Achievement Standards giving a total of 22 credits. The aims of the standards are to consolidate and extend students' ability in algebraic, graphical and computations skills, to extend students' ability to formulate problems in mathematical terms and advance students' understanding of the nature of mathematical reasoning.

**This is a NCEA Level 3 approved subject.**

## STANDARDS

Standards for this course will be selected from those listed below and are at the discretion of the HOLA  
 Level 2 Standards that contribute to Literacy and Numeracy are indicated by (L) = Literacy; (N) = Numeracy  
 Level 2 & 3 Standards that contribute to UE literacy requirements are indicated by (R) = Reading; (W) = Writing

## VOCATIONAL PATHWAYS

Vocational Pathway information helps with future career planning. Each Standard has been aligned to a potential Pathway, reflected by a tick in the relevant column of the table. "What is your pathway?" Please refer to page 5 in this book or pages 22 and 23 in the Level 1-3 Information Book for more information regarding Vocational Pathways.

STANDARDS						VOCATIONAL PATHWAYS					
Number	Subject Ref	Title	Int/Ext	Credits	CODES	Construction & Infrastructure	Manufacturing & Technology	Primary Industries	Service Industries	Social & Community Services	Creative Industries
<i>NCEA Internal Achievement Standards/Unit Standards</i>											
AS91587	Mathematics 3.15	Apply systems of simultaneous equations in solving problems	Internal	3		✓	✓	✓			
AS91575	Mathematics 3.3	Apply trigonometric methods in solving problems	Internal	4		✓	✓				
AS91574	Mathematics 3.2	Apply linear programming methods in solving problems	Internal	3		✓	✓	✓			
<i>NCEA External Achievement Standards</i>											
AS91578	Mathematics 3.6	Apply differentiation methods in solving problems	External	6		✓	✓	✓		✓	
AS91579	Mathematics 3.7	Apply integration methods in solving problems	External	6		✓	✓	✓			
<i>Possible Credits Available</i>			22 Credits								

# CAREER PATHWAYS (CAP3)

## COURSE INFORMATION

Qualification and level:	NCEA Level 3
Course Prerequisites:	It is preferred that students have completed NCEA Level 2. However, students must have approval for this course through consultation with a member of the Senior Leadership Team or their Whanau Leader. All student will be interviewed by the Vocational Pathways Manager/Careers Advisor
Fieldwork:	A work experience placement through the Gateway programme may be offered to students who did not complete one in Y12. Students are required to complete 30-40 hours of un-paid work experience in a relevant setting during the April or July holidays.
Approximate Course Costs:	Nil
Course Leads to:	Employment, apprenticeship, or further education.
Course Provider/Assessor:	Botany Downs Secondary College
Teacher in charge of subject:	Mrs Malone
HOLA in charge of subject:	

## COURSE OUTLINE

The Career Pathways course is a vocational programme designed to equip students with life and industry skills which will help them when they leave school. Students will complete the core Standards in class and, if not undertaken in Year 12, may be offered a Gateway work experience placement.

Work placements will vary depending on students' interests and the availability of places. Gateway provides opportunities in a range of fields including, but not limited to: Retail, Hospitality, Banking, Fashion, Hair and Beauty, Automotive, Electrical, Health and Child Care.

## STANDARDS

Standards for this course will be selected from those listed below and are at the discretion of the HOLA  
 Level 2 Standards that contribute to Literacy and Numeracy are indicated by (L) = Literacy: (N) = Numeracy  
 Level 2 & 3 Standards that contribute to UE literacy requirements are indicated by (R) = Reading: (W) = Writing

## VOCATIONAL PATHWAYS

Vocational Pathway information helps with future career planning. Each Standard has been aligned to a potential Pathway, reflected by a tick in the relevant column of the table. "What is your pathway?" Please refer to page 5 in this book or pages 22 and 23 in the Level 1-3 Information Book for more information regarding Vocational Pathways.

STANDARDS						VOCATIONAL PATHWAYS					
Number	Subject Ref	Title	Int/Ext	Credits	CODES	Construction & Infrastructure	Manufacturing & Technology	Primary Industries	Service Industries	Social & Community Services	Creative Industries
<i>NCEA Internal Achievement Standards/Unit Standards</i>											
US 4251		Plan a career pathway	Internal	3							
US 1304		Communicate with people from other cultures	Internal	2							
US 9681		Contribute within a team or group which has an objective	Internal	3							
US 1279		Write in plain English	Internal	3							
US 1307		Speak to a known audience in a predictable situation	Internal	3							
US 1296		Interview in an informal situation	Internal	3							
<i>Possible Credits Available</i>				17 Credits							

# CHEMISTRY (CHE3)

## COURSE INFORMATION

Qualification and level:	NCEA Level 3
Course Prerequisites:	At least 2 or 3 external papers achieved in NCEA Level 2 Chemistry and at least 12 credits in Level 2 Mathematics. Students that passed internal chemistry papers yet do not meet the above prerequisites will not be signed into the course.
Fieldwork:	Nil
Approximate Course Costs:	\$20.00 Online Resources.
Course Leads to:	Tertiary Study in Chemistry or related fields
Course Provider/Assessor:	Botany Downs Secondary College
Teacher in charge of subject:	Mrs Sharma
HOLA in charge of subject:	Mr Kumar

## COURSE OUTLINE

Chemistry is the study of the composition and properties of matter, and the changes it undergoes. Students will sit the NCEA Level 3 Chemistry examinations at the end of the course. Outstanding students may choose to sit the Chemistry Scholarship (Level 4) exam at the end of the course.

Students will start the year with the oxidation—reduction processes internal assessment followed by the three topics leading towards the school practice examinations for externals. The remaining spectroscopy internal will be done in September before the school practice examinations.

**This is a NCEA Level 3 approved subject.**

## STANDARDS

Standards for this course will be selected from those listed below and are at the discretion of the HOLA  
Level 2 Standards that contribute to Literacy and Numeracy are indicated by (L) = Literacy; (N) = Numeracy  
Level 2 & 3 Standards that contribute to UE literacy requirements are indicated by (R) = Reading; (W) = Writing

## VOCATIONAL PATHWAYS

Vocational Pathway information helps with future career planning. Each Standard has been aligned to a potential Pathway, reflected by a tick in the relevant column of the table. "What is your pathway?" Please refer to page 5 in this book or pages 22 and 23 in the Level 1-3 Information Book for more information regarding Vocational Pathways.

STANDARDS						VOCATIONAL PATHWAYS					
Number	Subject Ref	Title	Int/Ext	Credits	CODES	Construction & Infrastructure	Manufacturing & Technology	Primary Industries	Service Industries	Social & Community Services	Creative Industries
<i>NCEA Internal Achievement Standards/Unit Standards</i>											
AS91388	Chemistry 3.2	Demonstrate understanding of spectroscopic data in chemistry.	Internal	3		✓	✓	✓		✓	
AS91393	Chemistry 3.7	Describe oxidation-reduction processes.	Internal	3		✓	✓	✓		✓	
<i>NCEA External Achievement Standards</i>											
AS91390	Chemistry 3.4	Demonstrate understanding of thermochemical principles and the properties of particles and substances.	External	5		✓	✓	✓		✓	
AS91391	Chemistry 3.5	Demonstrate understanding of the properties of organic compounds.	External	5		✓	✓	✓	✓	✓	
AS91392	Chemistry 3.7	Demonstrate understanding of equilibrium principles in aqueous systems.	External	5		✓	✓	✓		✓	
<i>Possible Credits Available</i>				21 Credits							

# CLASSICAL STUDIES (CLS3)

## COURSE INFORMATION

Qualification and level:	NCEA Level 3
Course Prerequisites:	12 credits in one of NCEA Level 2 Achievement Standards History, Classical Studies or English (including at least <u>one</u> of AS91233, AS91234, AS91098, AS91100, or AS91101)
Fieldwork:	Nil
Approximate Course Costs:	Nil
Course Leads to:	Tertiary Study in Ancient History, Classical Studies, English, and is useful for Law.
Course Provider/Assessor:	Botany Downs Secondary College
Teacher in charge of subject:	Mr Mihajlov
HOLA in charge of subject:	Mr Andrew

## COURSE OUTLINE

Classical Studies is a holistic study of the Greek and Roman civilisations. It covers philosophy, art, architecture, society, politics, drama, literature and history. Level 3 Classical Studies focuses on introducing the ancient world to students and on developing the skills necessary to study ancient history. The study of ancient history involves looking at all aspects of a society in order to piece together what life would have been like, beliefs and values of the people of that time and the major historical events of the period. Possible topics covered are the campaigns and cultural fusion of Alexander the Great, the philosophies of Socrates, a study of Aristophanes' Comedies, and the study of Athenian Art and Architecture.

**This is a NCEA Level 3 approved subject.**

## STANDARDS

Standards for this course will be selected from those listed below and are at the discretion of the HOLA  
 Level 2 Standards that contribute to Literacy and Numeracy are indicated by (L) = Literacy; (N) = Numeracy  
 Level 2 & 3 Standards that contribute to UE literacy requirements are indicated by (R) = Reading; (W) = Writing

## VOCATIONAL PATHWAYS

Vocational Pathway information helps with future career planning. Each Standard has been aligned to a potential Pathway, reflected by a tick in the relevant column of the table. "What is your pathway?" Please refer to page 5 in this book or pages 22 and 23 in the Level 1-3 Information Book for more information regarding Vocational Pathways.

STANDARDS							VOCATIONAL PATHWAYS				
Number	Subject Ref	Title	Int/Ext	Credits	CODES	Construction & Infrastructure	Manufacturing & Technology	Primary Industries	Service Industries	Social & Community Services	Creative Industries
<i>NCEA Internal Achievement Standards/Unit Standards</i>											
AS91397	Classical Studies 3.4	Demonstrate understanding of significant ideology(ies) in the classical world.	Internal	6	R	✓	✓		✓	✓	✓
AS91398	Classical Studies 3.5	Demonstrate understanding of the lasting influences of the classical world on other cultures across time.	Internal	6	R	✓	✓		✓	✓	✓
<i>NCEA External Achievement Standards</i>											
AS91394	Classical Studies 3.1	Analyse ideas and values of the classical world.	External	4	R/W	✓	✓		✓	✓	✓
AS91395	Classical Studies 3.2	Analyse the significance of a work(s) of art in the classical world.	External	4	R/W	✓	✓		✓	✓	✓
AS91396	Classical Studies 3.3	Analyse the impact of a significant historical figure on the classical world.	External	6	R/W	✓	✓		✓	✓	✓
				<i>Possible Credits Available</i>		26 Credits					



# DANCE (DAN3)

## COURSE INFORMATION

Qualification and level:	NCEA Level 3
Course Prerequisites:	Level 2 Dance, Level 2 English
Fieldwork:	\$35
Approximate Course Costs:	\$50
Course Leads to:	Tertiary Study
Course Provider/Assessor:	Botany Downs Secondary College
Teacher in charge of subject:	Mrs Rakanui
HOLA in charge of subject:	Mrs Rakanui

## COURSE OUTLINE

The Level 3 Dance course will focus on the following: Choreography, Dance Perspectives, and Dance for Performance. Dance is a subject which explores a range of Dance practices, Choreographic techniques, and Dance theories. Dance at Level 3 is both physically demanding and mentally challenging. Students are required to dance daily as well as complete a daily journal.

The Level 3 dance programme has a strong New Zealand focus, students will work with New Zealand Choreographers and guest tutors. Students will develop a broad range of dance techniques. A small sample would include; Contemporary Dance, Composition and Choreography, Ethnic Dance, and Social Dance.

Students are required to rehearse as part of their on-going homework in this subject and are required to view a minimum of two live dance performances.

**This is a NCEA Level 3 approved subject.**

## STANDARDS

Standards for this course will be selected from those listed below and are at the discretion of the HOLA  
 Level 2 Standards that contribute to Literacy and Numeracy are indicated by (L) = Literacy; (N) = Numeracy  
 Level 2 & 3 Standards that contribute to UE literacy requirements are indicated by (R) = Reading; (W) = Writing

## VOCATIONAL PATHWAYS

Vocational Pathway information helps with future career planning. Each Standard has been aligned to a potential Pathway, reflected by a tick in the relevant column of the table. "What is your pathway?" Please refer to page 5 in this book or pages 22 and 23 in the Level 1-3 Information Book for more information regarding Vocational Pathways.

STANDARDS						VOCATIONAL PATHWAYS					
Number	Subject Ref	Title	Int/Ext	Credits	CODES	Construction & Infrastructure	Manufacturing & Technology	Primary Industries	Service Industries	Social & Community Services	Creative Industries
<i>NCEA Internal Achievement Standards/Unit Standards</i>											
AS91588	Dance 3.1	Produce a dance to realise a concept	Internal	8		✓	✓		✓	✓	✓
AS91589	Dance 3.2	Choreograph a dance to develop and resolve ideas	Internal	4		✓	✓		✓	✓	✓
AS91590	Dance 3.3	Perform in a choreographed group dance to an audience	Internal	4		✓	✓		✓	✓	✓
AS91591	Dance 3.4	Perform a group dance	Internal	4		✓	✓		✓	✓	✓
AS91592	Dance 3.5	Perform a repertoire of Dance	Internal	6		✓	✓		✓	✓	✓
AS91593	Dance 3.6	Demonstrate understanding of dance performance practices	Internal	4		✓	✓		✓	✓	✓
<i>NCEA External Achievement Standards</i>											
AS91594	Dance 3.7	Critically analyse and respond to a dance performance	External	4		✓	✓		✓	✓	✓
				<i>Possible Credits Available</i>		24 Credits					

# DESIGN & VISUAL COMMUNICATION (DVC3)

## COURSE INFORMATION

Qualification and level:	NCEA Level 3
Course Prerequisites:	At least 13 credits in NCEA Level 2 DVC or 20 credits in Level 1 DVC
Fieldwork:	Nil
Approximate Course Costs:	\$40
Course Leads to:	Tertiary Study in Design and Visual Communication
Course Provider/Assessor:	Botany Downs Secondary College
Teacher in charge of subject:	Mr Achary
HOLA in charge of subject:	Mr Achary

## COURSE OUTLINE

Level 3 Design & Visual Communication will build on the experiences of Level 2 DVC and will enable students to apply their acquired knowledge to an area of their choice (Spatial or Product design). The design opportunities will enable students to explore areas of DVC that better suit their interests and strengths. This will enable them to achieve in both the internal and external achievement standards through the production of design work, working drawings, models and through testing and evaluation. They will also plan and produce illustrative presentation portfolios through smart planning. Innovation and authentic ideation is a critical part of the Level 3 DVC course.

Students can also enter for scholarship in DVC if their portfolio of work and presentation shows innovative design practice and application of advanced graphics skills.

**This is a NCEA Level 3 approved subject.**

## STANDARDS

Standards for this course will be selected from those listed below and are at the discretion of the HOLA  
 Level 2 Standards that contribute to Literacy and Numeracy are indicated by (L) = Literacy; (N) = Numeracy  
 Level 2 & 3 Standards that contribute to UE literacy requirements are indicated by (R) = Reading; (W) = Writing

## VOCATIONAL PATHWAYS

Vocational Pathway information helps with future career planning. Each Standard has been aligned to a potential Pathway, reflected by a tick in the relevant column of the table. "What is your pathway?" Please refer to page 5 in this book or pages 22 and 23 in the Level 1-3 Information Book for more information regarding Vocational Pathways.

STANDARDS							VOCATIONAL PATHWAYS					
Number	Subject Ref	Title	Int/Ext	Credits	CODES	Construction & Infrastructure	Manufacturing & Technology	Primary Industries	Service Industries	Social & Community Services	Creative Industries	
<i>NCEA Internal Achievement Standards/Unit Standards</i>												
AS91629 Or AS91630	Graphics 3.32	Resolve a spatial design through graphics practice	Internal	6		✓	✓				✓	
	Graphics 3.33	Resolve a product design through graphics practice	Internal	6		✓	✓				✓	
AS91628	Graphics 3.31	Develop a visual presentation that exhibits a design outcome to an audience	Internal	6		✓	✓	✓			✓	
<i>NCEA External Achievement Standards</i>												
AS91627	Graphics 3.30	Initiate design ideas through exploration	External	4		✓	✓	✓	✓		✓	
AS91631	Graphics 3.34	Produce working drawings to communicate production details for a complex design	External	6		✓	✓	✓			✓	
<i>Possible Credits Available</i>				22 Credits								

# DIGITAL TECHNOLOGIES WITH PROGRAMMING (DIP3)

## COURSE INFORMATION

Qualification and level:	NCEA Level 3
Course Prerequisites:	To have achieved in the two programming standards in 12DIP plus at least one other standard from 12DIP – or at HOSA discretion.
Fieldwork:	Nil
Approximate Course Costs:	\$10 Online course, \$10 USB memory stick
Course Leads to:	Tertiary study in computer science or employment in IT/Business
Course Provider/Assessor:	Botany Downs Secondary College
Teacher in charge of subject:	Mr Patchigalla
HOLA in charge of subject:	Mr Achary

## COURSE OUTLINE

This is a university approved subject suitable for academic students. It continues with computer programming but works on designing object-oriented programming that are modular and have a graphical user interface. It also looks at key areas of computer science such as Software Engineering and Intelligent Systems. Students will also design the concept for a web site and then use complex tools and techniques of HTML5/CSS3/JavaScript to create a website for a client.

Several NZ Universities including Auckland University give recognition for prior learning (RPL) to students who have achieved AS91610, AS91636 with Merit or Excellence, they do not need to enrol for COMPSCI 101: Principles of Programming in their first semester or COMPSCI 105: Principles of Computer Science in their second semester.

**Please note students can only take a maximum of two subjects from DIT3, DIP3, and one of TEM3/TET3/TEF3**

**This is a NCEA Level 3 approved subject.**

## STANDARDS

Standards for this course will be selected from those listed below and are at the discretion of the HOLA  
 Level 2 Standards that contribute to Literacy and Numeracy are indicated by (L) = Literacy; (N) = Numeracy  
 Level 2 & 3 Standards that contribute to UE literacy requirements are indicated by (R) = Reading; (W) = Writing

## VOCATIONAL PATHWAYS

Vocational Pathway information helps with future career planning. Each Standard has been aligned to a potential Pathway, reflected by a tick in the relevant column of the table. "What is your pathway?" Please refer to page 5 in this book or pages 22 and 23 in the Level 1-3 Information Book for more information regarding Vocational Pathways.

STANDARDS						VOCATIONAL PATHWAYS					
Number	Subject Ref	Title	Int/Ext	Credits	CODES	Construction & Infrastructure	Manufacturing & Technology	Primary Industries	Service Industries	Social & Community Services	Creative Industries
<i>NCEA Internal Achievement Standards/Unit Standards</i>											
AS91633	Digital Technologies	Implement complex procedures to develop a relational database embedded in a specified digital outcome	Internal	6			✓	✓			
AS91637	Digital Technologies	Develop a complex computer program for a specified task	Internal	6			✓				✓
AS91642	Digital Technologies	Implement procedures for administering a wide area network	Internal	4							
<i>NCEA External Achievement Standards</i>											
AS91636	Digital Technologies	Demonstrate understanding of areas of computer science	External	4			✓				
<i>Possible Credits Available</i>						20 Credits					

# DIGITAL TECHNOLOGIES (DIT3)

## COURSE INFORMATION

Qualification and level:	NCEA Level 3
Course Prerequisites:	13 credits in DIT2/DIP2 including 2.3 or HOSA discretion
Fieldwork:	Nil
Approximate Course Costs:	\$10 Online course, \$10 USB memory stick
Course Leads to:	Tertiary Study ICT related areas
Course Provider/Assessor:	Botany Downs Secondary College
Teacher in charge of subject:	Mr Patchigalla
HOLA in charge of subject:	Mr Achary

## COURSE OUTLINE

This is a university approved subject. This course is designed to develop complex skills in Digital Technologies and is focused on media (web) and database development. Students will acquire a range of practical skills and demonstrate these using various software applications as required to produce a solution for a project. Specifically, students will develop skills associated with writing JavaScript, complex tools and techniques in HTML, CSS and creating and managing relational databases. Software used will include Photoshop, Illustrator, phpMyAdmin, Notepad++ or similar applications.

**Please note students can only take a maximum of two subjects from DIT3, DIP3, and one of TEM3/TET3/TEF3**

**This is a NCEA Level 3 approved subject.**

## STANDARDS

Standards for this course will be selected from those listed below and are at the discretion of the HOLA  
 Level 2 Standards that contribute to Literacy and Numeracy are indicated by (L) = Literacy; (N) = Numeracy  
 Level 2 & 3 Standards that contribute to UE literacy requirements are indicated by (R) = Reading; (W) = Writing

## VOCATIONAL PATHWAYS

Vocational Pathway information helps with future career planning. Each Standard has been aligned to a potential Pathway, reflected by a tick in the relevant column of the table. "What is your pathway?" Please refer to page 5 in this book or pages 22 and 23 in the Level 1-3 Information Book for more information regarding Vocational Pathways.

STANDARDS						VOCATIONAL PATHWAYS					
Number	Subject Ref	Title	Int/Ext	Credits	CODES	Construction & Infrastructure	Manufacturing & Technology	Primary Industries	Service Industries	Social & Community Services	Creative Industries
<i>NCEA Internal Achievement Standards/Unit Standards</i>											
AS91610	Technology 3.3	Develop a conceptual design considering fitness for purpose in the broadest sense	Internal	6		✓	✓	✓			✓
AS91633	Digital Technologies	Implement complex procedures to develop a relational database embedded in a specified digital outcome	Internal	6			✓	✓			
AS91634	Digital Technologies	Demonstrate understanding of complex concepts of digital media (offered to student enrolled in DIP3)	Internal	4							
AS91635	Digital Technologies	Implement complex procedures to produce a specified digital media outcome	Internal	4			✓		✓		✓
<i>NCEA External Achievement Standards</i>											
AS 91632	Digital Technologies	Demonstrate understanding of complex concepts of information systems in an organisation	External	4			✓	✓	✓		
				<i>Possible Credits Available</i>							
				18-20 Credits							

# DRAMA (DRA3)

## COURSE INFORMATION

Qualification and level:	NCEA Level 3
Course Prerequisites:	14 credits in NCEA Level 2 Drama or HOD approval
Fieldwork:	Students will be required to see at least two productions in preparation for the external exam - productions to be advised.
Approximate Course Costs:	Fieldwork expenses approximately \$40
Course Leads to:	Scholarship and Tertiary Study
Course Provider/Assessor:	Botany Downs Secondary College
Teacher in charge of subject:	Ms Hood
HOLA in charge of subject:	Ms Hood

## COURSE OUTLINE

This course is a progression from Level 2 Drama. The Level 3 course is an exciting and challenging course which will assist you in further developing your skills of collaboration, creativity, innovation and interpretation. The course provides an opportunity to use and explore the elements, conventions, techniques and technologies in specific dramatic forms, both practically and in written analysis. You have the opportunity in the course to become directors, designers, playwrights and producers of your own work and that of other students. You will rehearse and perform works in a range of dramatic forms, as well as respond to the work of others. Class work is a mixture of group and individual tasks, and it is important for you to work co-operatively in a group, as well as an independently. At Level 3 the content and contexts for exploration and performance are more challenging, enabling you to develop your thinking and response to the work in practical performance. Leadership and collaboration opportunities increase as you are able to mentor younger students, particularly in co-curricular activities. Skills acquired in the course translate well to a number of fields and prepare students to confidently present themselves as creative and innovative thinkers and learners. Please be aware that most Achievement Standards will be assessed during public evening performances, and audiences are welcome to view these performances. You will be expected to attend at least two professional live theatre productions during the year. For those students who are interested in studying Drama, this knowledge and experience underpins many of the skills essential in a number of careers such as psychologist, courtroom lawyer, positions in the arts and media, advertising and print media. Level 3 Drama develops skills which will assist you in your career aspirations.

**This is a NCEA Level 3 approved subject.**

## STANDARDS

Standards for this course will be selected from those listed below and are at the discretion of the HOLA  
 Level 2 Standards that contribute to Literacy and Numeracy are indicated by (L) = Literacy: (N) = Numeracy  
 Level 2 & 3 Standards that contribute to UE literacy requirements are indicated by (R) = Reading: (W) = Writing

## VOCATIONAL PATHWAYS

Vocational Pathway information helps with future career planning. Each Standard has been aligned to a potential Pathway, reflected by a tick in the relevant column of the table. "What is your pathway?" Please refer to page 5 in this book or pages 22 and 23 in the Level 1-3 Information Book for more information regarding Vocational Pathways.

STANDARDS						VOCATIONAL PATHWAYS					
Number	Subject Ref	Title	Int/Ext	Credits	CODES	Construction & Infrastructure	Manufacturing & Technology	Primary Industries	Service Industries	Social & Community Services	Creative Industries
<i>NCEA Internal Achievement Standards/Unit Standards</i>											
AS91512	Drama 3.1	Interpret scripted text to integrate drama techniques in performance	Internal	4	R						✓
AS91513	Drama 3.2	Devise and perform a drama to realise a concept	Internal	5					✓		✓
AS91515	Drama 3.4	Select and use complex performance skills associate with a drama form or period	Internal	4	R						✓
AS91516	Drama 3.5	Demonstrate understanding of the work of a drama or theatre theorist or practitioner	Internal	4	R						✓
AS91517	Drama 3.6	Perform a substantial acting role in a significant production	Internal	5	R						✓
AS91519	Drama 3.8	Script a drama suitable for live performance	Internal	5	W				✓		✓
AS91520	Drama 3.9	Direct a drama performance	Internal	5	R				✓		✓
<i>NCEA External Achievement Standards</i>											
AS91514	Drama 3.3	Interpret a prescribed text to demonstrate knowledge of a theatre form or period	External	4	R/W						✓
AS91518	Drama 3.7	Demonstrate understanding of live performance	External	4	W						✓
<i>Possible Credits Available</i>						24 Credits					

# EARLY CHILDHOOD EDUCATION (ECE3)

## COURSE INFORMATION

Qualification and level:	NCEA Level 3
Course Prerequisites:	10 credits at Year 12ECE or an interest in Early Childhood
Fieldwork:	Visits to Early Childhood centres
Approximate Course Costs:	Nil
Course Leads to:	ECE based tertiary courses
Course Provider/Assessor:	MIT
Teacher in charge of subject:	Mrs McGregor
HOLA in charge of subject:	Mr Saville

## COURSE OUTLINE

The MIT Certificate of Achievement in Early Childhood Education Level 3 is designed for Year 13 students. These units follow on from the Level 2 Certificate of Achievement in Early Childhood Education and continue to build students' knowledge and skills in the education and care of young children in early childhood education settings. This course aims to prepare students to advance into higher level early childhood education and care. The programme is made up of one compulsory Unit Standard and a choice of three options at Level 3. Students will need to complete a minimum of 14 credits to achieve at Level 3. Students will need to have the opportunity to participate in an early childhood setting to meet the assessment requirements on this program.

## STANDARDS

Standards for this course will be selected from those listed below and are at the discretion of the HOLA  
 Level 2 Standards that contribute to Literacy and Numeracy are indicated by (L) = Literacy; (N) = Numeracy  
 Level 2 & 3 Standards that contribute to UE literacy requirements are indicated by (R) = Reading; (W) = Writing

## VOCATIONAL PATHWAYS

Vocational Pathway information helps with future career planning. Each Standard has been aligned to a potential Pathway, reflected by a tick in the relevant column of the table. "What is your pathway?" Please refer to page 5 in this book or pages 22 and 23 in the Level 1-3 Information Book for more information regarding Vocational Pathways.

STANDARDS						VOCATIONAL PATHWAYS					
Number	Subject Ref	Title	Int/Ext	Credits	CODES	Construction & Infrastructure	Manufacturing & Technology	Primary Industries	Service Industries	Social & Community Services	Creative Industries
<i>NCEA Internal Achievement Standards/Unit Standards</i>											
US10026	ECE Level 3	Demonstrate knowledge of the development and learning of children and its relevance to an ECE service.	Internal	5		✓	✓		✓		
US26707	ECE Level 3	Describe the value of play and create resources for children's development and learning in an ECE service	Internal	6		✓	✓		✓		
US26708	ECE Level 3	Develop reciprocal and responsive relationships with a child in an ECE service	Internal	5		✓	✓		✓		
US10019	ECE Level 3	Describe and contribute to safe practices and a safe environment for a child in an ECE service	Internal	4		✓	✓		✓		
				<i>Possible Credits Available</i>	20						

# ECONOMICS (ECO3)

## COURSE INFORMATION

Qualification and level:	NCEA Level 3
Course Prerequisites:	12 credits in NCEA Level 2 Economics (including one external) or at the discretion of HOD Commerce.
Fieldwork:	To Wellington: Reserve Bank of NZ ,Treasury NZ , NZ Statistics to be confirmed or Waihi Gold Mine
Approximate Course Costs:	Course Workbook - \$44 (2 Books) plus elearn economics web resource
Course Leads to:	Tertiary Study in commerce/business, marketing, construction economics (quantity surveying), forestry, farm management, journalism and teaching. Careers in manufacturing, transport, communications, banking, insurance, investment and retailing industries, as well as in government agencies, consulting and charitable organisations
Course Provider/Assessor:	Botany Downs Secondary College
Teacher in charge of subject:	Mr Sharma
HOLA in charge of subject:	Mr Andrew

## COURSE OUTLINE

Level 3 Economics splits into two sections. It starts by building upon Level 2 Economics by looking at Aggregate Economics, often referred to as macroeconomics. This area investigates the whole economy, looking at GDP, Inflation, International trade and government policies associated with these issues. The course then moves into microeconomics. Students focus on the economics of individual markets and how the characteristics of and influences on these markets affect their ability to efficiently answer the central economic problem of scarcity.

**This is a NCEA Level 3 approved subject.**

## STANDARDS

Standards for this course will be selected from those listed below and are at the discretion of the HOLA  
 Level 2 Standards that contribute to Literacy and Numeracy are indicated by (L) = Literacy: (N) = Numeracy  
 Level 2 & 3 Standards that contribute to UE literacy requirements are indicated by (R) = Reading: (W) = Writing

## VOCATIONAL PATHWAYS

Vocational Pathway information helps with future career planning. Each Standard has been aligned to a potential Pathway, reflected by a tick in the relevant column of the table. "What is your pathway?" Please refer to page 5 in this book or pages 22 and 23 in the Level 1-3 Information Book for more information regarding Vocational Pathways.

STANDARDS						VOCATIONAL PATHWAYS					
Number	Subject Ref	Title	Int/Ext	Credits	CODES	Construction & Infrastructure	Manufacturing & Technology	Primary Industries	Service Industries	Social & Community Services	Creative Industries
<i>NCEA Internal Achievement Standards/Unit Standards</i>											
AS91401	Economics 3.3	Demonstrate understanding of micro-economic concepts	Internal	5	R				✓		
AS91402	Economics 3.4	Demonstrate understanding of government interventions to correct market failures	Internal	5	R			✓			
<i>NCEA External Achievement Standards</i>											
AS91400	Economics 3.2	Demonstrate understanding of the efficiency of different market structures using marginal analysis	External	4	R/W			✓	✓		
AS91403	Economics 3.5	Demonstrate understanding of macro-economic influences on the New Zealand economy	External	6	R/W			✓	✓		
<i>Possible Credits Available</i>				20 Credits							



# ELECTRONICS (ELE3)

## COURSE INFORMATION

Qualification and level:	NCEA Level 3
Course Prerequisites:	14 credits in NCET Level 2 Electronics including US 18239 (circuit theory) and 12 Credits in Level 2 Mathematics (Achievement Standards) <b>OR</b> 10 or more credits in Year 12 Physics including Electricity (AS90257)
Fieldwork:	Workplace/tertiary provider visits as possible (TBA)
Approximate Course Costs:	NCET \$15
Course Leads to:	Tertiary study in electronics and electrical engineering
Course Provider/Assessor:	Botany Downs Secondary College
Teacher in charge of subject:	Mr Raj
HOLA in charge of subject:	Mr Kumar

## COURSE OUTLINE

Electronics is the study and design of control, communication and computing devices that depend on electricity in circuits that contain different components. This course is for people who want to understand more about electronics or pursue a career in this field. Students will learn how to construct electronic circuits and use these to develop new products. They also learn how semi-conductor devices work, study the digital and analogue concepts and use these to understand and develop communication systems and investigate electronic product reliability. This course builds upon the knowledge and skills gained in the Level 2 course. It covers the function and use of additional electronic components and the construction of more advanced circuits. Analogue and digital electronics are covered in more detail as is the generation and transmission of electronic signals. Finally, programmable microcontrollers are studied in the context of mechatronics (smart machines). This course is now offering Achieved, Merit and Excellence grades.

## STANDARDS

Standards for this course will be selected from those listed below and are at the discretion of the HOLA  
Level 2 Standards that contribute to Literacy and Numeracy are indicated by (L) = Literacy; (N) = Numeracy  
Level 2 & 3 Standards that contribute to UE literacy requirements are indicated by (R) = Reading; (W) = Writing

## VOCATIONAL PATHWAYS

Vocational Pathway information helps with future career planning. Each Standard has been aligned to a potential Pathway, reflected by a tick in the relevant column of the table. "What is your pathway?" Please refer to page 5 in this book or pages 22 and 23 in the Level 1-3 Information Book for more information regarding Vocational Pathways.

STANDARDS						VOCATIONAL PATHWAYS					
Number	Subject Ref	Title	Int/Ext	Credits	CODES	Construction & Infrastructure	Manufacturing & Technology	Primary Industries	Service Industries	Social & Community Services	Creative Industries
<i>NCEA Internal Achievement Standards/Unit Standards</i>											
US26122	-	Demonstrate knowledge of and build circuits using digital electronic devices that interface with ADC and DAC functions	Internal	3							
US26119	-	Construct, and report on the performance of a simple electronic programmable circuit.	Internal	4							
US26120	-	Describe and construct circuit to demonstrate the operation and properties of electronic devices.	Internal	3							
US26121	-	Plan, construct, modify, and report on an electronic prototype	Internal	6							
US26123	-	Demonstrate knowledge of the practical applications of logic circuits	Internal	3							
<i>Possible Credits Available</i>				19 Credits							

# ENGLISH - EXTENDED (ENE3)

## COURSE INFORMATION

Qualification and level:	NCEA Level 3
Course Prerequisites:	UE Literacy (5 reading and 5 writing credits at Level 2), as well as Achievement with Merit/ Excellence in at least two external English achievement standards, including unfamiliar text.
Fieldwork:	There may be attendance required at the occasional film and/or theatre performance.
Approximate Course Costs:	Workbook: \$20
Course Leads to:	Tertiary Study
Course Provider/Assessor:	Botany Downs Secondary College
Teacher in charge of subject:	Ms Rooke
HOLA in charge of subject:	Ms Logan

## COURSE OUTLINE

This is an academic course where the literature covered will be substantially more advanced than Level 2 English. This course is designed for students who wish to study English rich subjects at university, and may be considering taking Scholarship English. Classes are discussion based and students are expected to read widely and undertake independent study.

This course involves a detailed Shakespeare unit of work.

Entry into this course is at HOLA discretion.

**This is a NCEA Level 3 approved subject.**

## STANDARDS

Standards for this course will be selected from those listed below and are at the discretion of the HOLA  
 Level 2 Standards that contribute to Literacy and Numeracy are indicated by (L) = Literacy; (N) = Numeracy  
 Level 2 & 3 Standards that contribute to UE literacy requirements are indicated by (R) = Reading; (W) = Writing

## VOCATIONAL PATHWAYS

Vocational Pathway information helps with future career planning. Each Standard has been aligned to a potential Pathway, reflected by a tick in the relevant column of the table. "What is your pathway?" Please refer to page 5 in this book or pages 22 and 23 in the Level 1-3 Information Book for more information regarding Vocational Pathways.

STANDARDS							VOCATIONAL PATHWAYS					
Number	Subject Ref	Title	Int/Ext	Credits	CODES	Construction & Infrastructure	Manufacturing & Technology	Primary Industries	Service Industries	Social & Community Services	Creative Industries	
<i>NCEA Internal Achievement Standards/Unit Standards</i>												
AS91475	English 3.4	Produce a selection of fluent and coherent writing	Internal	6	W	✓		✓	✓	✓	✓	
AS91476	English 3.5	Create and deliver a fluent and coherent oral text	Internal	3		✓	✓	✓	✓	✓	✓	
AS91477	English 3.6	Create a fluent and coherent visual text (TIC /HOLA permission needed)	Internal	3		✓		✓	✓	✓	✓	
AS91479	English 3.8	Develop an informed understanding of literature and/or language	Internal	4	R	✓		✓	✓	✓	✓	
<i>NCEA External Achievement Standards</i>												
AS91472	English 3.1	Respond critically to written text(s) studied	External	3	R/W	✓	✓	✓	✓	✓		
AS91473	English 3.2	Respond critically to visual text(s) studied	External	3	W	✓	✓	✓	✓	✓		
AS91474	English 3.3	Respond critically to unfamiliar texts	External	3	R/W	✓	✓	✓	✓	✓		
				<i>Possible Credits Available</i>		22 Credits						

# ENGLISH (ENG3)

## COURSE INFORMATION

Qualification and level:	NCEA Level 3
Course Prerequisites:	UE Literacy (5 reading and 5 writing credits at Level 2), as well as Achievement in at least two external English achievement standards.
Fieldwork:	There may be attendance required at the
Approximate Course Costs:	Workbook: \$20 Theatre/film attendance \$15
Course Leads to:	Tertiary Study
Course Provider/Assessor:	Botany Downs Secondary College
Teacher in charge of subject:	Ms Rooke
HOLA in charge of subject:	Ms Logan

## COURSE OUTLINE

This course is designed for students who have had success in Level 2 English and require Level 3 English for further tertiary study. This is a reading/writing and speaking based course and text units studied will require a more advanced level of critical response. Students are expected to read widely in their own time as well as complete independent study.

Two external standards are offered in this course. Students may be entered into 3.3 as an extension opportunity with HOLA/TIC approval.

Entry into this course is at HOLA discretion.

**This is a NCEA Level 3 approved subject.**

## STANDARDS

Standards for this course will be selected from those listed below and are at the discretion of the HOLA  
 Level 2 Standards that contribute to Literacy and Numeracy are indicated by (L) = Literacy; (N) = Numeracy  
 Level 2 & 3 Standards that contribute to UE literacy requirements are indicated by (R) = Reading; (W) = Writing

## VOCATIONAL PATHWAYS

Vocational Pathway information helps with future career planning. Each Standard has been aligned to a potential Pathway, reflected by a tick in the relevant column of the table. "What is your pathway?" Please refer to page 5 in this book or pages 22 and 23 in the Level 1-3 Information Book for more information regarding Vocational Pathways.

STANDARDS						VOCATIONAL PATHWAYS					
Number	Subject Ref	Title	Int/Ext	Credits	CODES	Construction & Infrastructure	Manufacturing & Technology	Primary Industries	Service Industries	Social & Community Services	Creative Industries
<i>NCEA Internal Achievement Standards/Unit Standards</i>											
AS91476	English 3.5	Create and deliver a fluent and coherent oral text	Internal	3		✓	✓	✓	✓	✓	✓
AS91478	English 3.7	Respond critically to significant connections across texts	Internal	4		✓	✓	✓	✓	✓	✓
AS91480	English 3.9	Respond critically to significant aspects of visual/oral text(s)	Internal	3							✓
<i>NCEA External Achievement Standards</i>											
AS91472	English 3.1	Respond critically to written text(s) studied	External	4	R/W	✓	✓	✓	✓	✓	
AS91473	English 3.2	Respond critically to visual text(s) studied	External	4	W	✓	✓	✓	✓	✓	
AS91474	English 3.3	Respond critically to unfamiliar texts	External	4	R/W	✓	✓	✓	✓	✓	
<i>Possible Credits Available</i>			22 Credits								

# ENGLISH - ALTERNATIVE (ENA3)

## COURSE INFORMATION

Qualification and level:	NCEA Level 3
Course Prerequisites:	UE Literacy (5 reading and 5 writing credits at Level 2). Failure to meet these prerequisites means HOLA permission required for entry.
Fieldwork:	
Approximate Course Costs:	Workbooks
Course Leads to:	University Entrance
Course Provider/Assessor:	Botany Downs Secondary College
Teacher in charge of subject:	Ms Rooke
HOLA in charge of subject:	Ms Logan

## COURSE OUTLINE

This course is designed to meet the needs of students who have achieved their UE literacy (5 reading and 5 writing credits) and would like to concentrate on internal Level 3 credits in English. This is a reading/writing/speaking based course. This course offers one external achievement standard.

Students who have not achieved their UE literacy credits will need to meet with the HOLA and TIC of Year 13 to discuss the possibility of a mixed Level 2 and 3 credit course. Please note: this will depend on the number of credits achieved. Students may be advised to take a Level 2 English course if fewer than 8 credits have been achieved for Level 2 English.

Please note: This course is not suitable for use as a Table A subject for The University of Auckland.

Entry into this course is at HOLA discretion.

**This is a NCEA Level 3 approved subject.**

## STANDARDS

Standards for this course will be selected from those listed below and are at the discretion of the HOLA  
 Level 2 Standards that contribute to Literacy and Numeracy are indicated by (L) = Literacy; (N) = Numeracy  
 Level 2 & 3 Standards that contribute to UE literacy requirements are indicated by (R) = Reading; (W) = Writing

## VOCATIONAL PATHWAYS

Vocational Pathway information helps with future career planning. Each Standard has been aligned to a potential Pathway, reflected by a tick in the relevant column of the table. "What is your pathway?" Please refer to page 5 in this book or pages 22 and 23 in the Level 1-3 Information Book for more information regarding Vocational Pathways.

STANDARDS						VOCATIONAL PATHWAYS					
Number	Subject Ref	Title	Int/Ext	Credits	CODES	Construction & Infrastructure	Manufacturing & Technology	Primary Industries	Service Industries	Social & Community Services	Creative Industries
<i>NCEA Internal Achievement Standards/Unit Standards</i>											
AS91476	English 3.5	Create and deliver a fluent and coherent oral text	Internal	3		✓	✓	✓	✓	✓	✓
AS41478	English 3.7	Respond critically to significant connections across texts	Internal	4		✓	✓	✓	✓	✓	✓
AS91480	English 3.9	Respond critically to significant aspects of visual/oral text(s)	Internal	3							✓
<i>NCEA External Achievement Standards</i>											
AS91472	English 3.1	Respond critically to written text(s) studied	External	4	R/W	✓	✓	✓	✓	✓	
AS91473	English 3.2	Respond critically to visual text(s) studied	External	4	W	✓	✓	✓	✓	✓	
<i>Possible Credits Available</i>			14 Credits								

# ENGLISH as an ADDITIONAL LANGUAGE (ENS3)

## COURSE INFORMATION

Qualification and level:	NCEA Level 3
Course Prerequisites:	Literacy at Level 2 or at discretion of HOLA
Fieldwork:	N/A
Approximate Course Costs:	Nil
Course Leads to:	Tertiary Study
Course Provider/Assessor:	Botany Downs Secondary College
Teacher in charge of subject:	Mrs Narain
HOLA in charge of subject:	Mrs Narain

## COURSE OUTLINE

This is a course designed to meet the needs of English language learners who have just achieved their literacy (5 reading and 5 writing credits) and who would like to concentrate on obtaining some Level 3 English credits which would be able to count towards gaining Level 3 credits and/or University Entrance. 2 internal and 1 external Level 3 assessments will be offered in English. Texts studied are more advanced and students will need to be able to respond critically to texts studied rather than just an analysis of a text.

For the internal assessments students will respond critically to significant connections across texts 3.7 and respond critically to significant aspects of visual/oral text(s) 3.9. For the external assessment students will complete a response to visual text essay 3.1.

PLEASE NOTE that this course ONLY offers 11 credits and cannot be used as an approved subject (requiring 14 credits) for University Entrance. Credits gained from this course may also be used towards the Academic English Language Requirement (AELR) for the University of Auckland.

## STANDARDS

Standards for this course will be selected from those listed below and are at the discretion of the HOLA  
 Level 2 Standards that contribute to Literacy and Numeracy are indicated by (L) = Literacy; (N) = Numeracy  
 Level 2 & 3 Standards that contribute to UE literacy requirements are indicated by (R) = Reading; (W) = Writing

## VOCATIONAL PATHWAYS

Vocational Pathway information helps with future career planning. Each Standard has been aligned to a potential Pathway, reflected by a tick in the relevant column of the table. "What is your pathway?" Please refer to page 5 in this book or pages 22 and 23 in the Level 1-3 Information Book for more information regarding Vocational Pathways.

STANDARDS						VOCATIONAL PATHWAYS					
Number	Subject Ref	Title	Int/Ext	Credits	CODES	Construction & Infrastructure	Manufacturing & Technology	Primary Industries	Service Industries	Social & Community Services	Creative Industries
<i>NCEA Internal Achievement Standards/Unit Standards</i>											
AS41478	English 3.7	Respond critically to significant connections across texts	Internal	4		✓	✓	✓	✓	✓	✓
AS91480	English 3.9	Respond critically to significant aspects of visual/oral text(s)	Internal	3							✓
<i>NCEA External Achievement Standards</i>											
AS91473	English 3.2	Respond critically to visual text(s) studied	External	4	W	✓	✓	✓	✓	✓	
<i>Possible Credits Available</i>			11 Credits								

# FINANCIAL STUDIES (FIN3)

## COURSE INFORMATION

Qualification and level:	NCEA Level 3
Course Prerequisites:	65 credits at NCEA level 2 including 8 credits in Level 2 Maths. Students who do not meet the prerequisites may make an application for this course or at the discretion of HOD Commerce.
Fieldwork:	To be advised
Approximate Course Costs:	\$20 (online FLP learning resource)
Course Leads to:	Further study in Finance, Business, Commerce programmes
Course Provider/Assessor:	Botany Downs Secondary College
Teacher in charge of subject:	Mr Sharma
HOLA in charge of subject:	Mr Andrew

## COURSE OUTLINE

The course aims to foster financial understanding, improve investor skills, and provide a format for designing a life strategy. It takes a more analytical approach than the Financial Literacy program and is expected to qualify for NCEA credits. Level 3 Finance covers such topics as investments, financial planning, student loans, external influences on investment decisions. Level 3 Finance is about personal financial management for the future where as Level 2 Financial Literacy is about personal financial management for the present.

## STANDARDS

Standards for this course will be selected from those listed below and are at the discretion of the HOLA  
 Level 2 Standards that contribute to Literacy and Numeracy are indicated by (L) = Literacy; (N) = Numeracy  
 Level 2 & 3 Standards that contribute to UE literacy requirements are indicated by (R) = Reading; (W) = Writing

## VOCATIONAL PATHWAYS

Vocational Pathway information helps with future career planning. Each Standard has been aligned to a potential Pathway, reflected by a tick in the relevant column of the table. "What is your pathway?" Please refer to page 5 in this book or pages 22 and 23 in the Level 1-3 Information Book for more information regarding Vocational Pathways.

STANDARDS						VOCATIONAL PATHWAYS					
Number	Subject Ref	Title	Int/Ext	Credits	CODES	Construction & Infrastructure	Manufacturing & Technology	Primary Industries	Service Industries	Social & Community Services	Creative Industries
<i>NCEA Internal Achievement Standards/Unit Standards</i>											
28100	-	Demonstrate and apply knowledge for Credit for PFM	Internal	3							
28102	-	Demonstrate knowledge of personal income, credit, and the impact of employment decisions on them	Internal	5							
28103	-	Set a complex personal financial goal and plan its implementation	Internal	3							
28104	-	Analyse and interpret financial statements	Internal	3							
28105	-	Demonstrate knowledge of risk, return and diversification	Internal	3							
28106	-	Identify requirements for a financial record system	Internal	3							
<i>Possible Credits Available</i>				20 Credits							

# FOOD & HOSPITALITY (FAH3)

## COURSE INFORMATION

Qualification and level:	NCEA Level 3
Course Prerequisites:	14 credits in NCEA Level 2 Technology / FAH or Level 1/2 Technology or HOLA approval.
Fieldwork:	Nil
Approximate Course Costs:	\$150 (basic course ingredients to be supplied, students may also be asked to bring food items). Competition Fee \$35 (optional)
Course Leads to:	Tertiary Study at MIT / AUT or other - Hospitality / Catering / Management / Modern Apprenticeship opportunity
Course Provider/Assessor:	Botany Downs Secondary College
Teacher in charge of subject:	Mrs Thomson
HOLA in charge of subject:	Mr Achary

## COURSE OUTLINE

This course is a continuation of Level 2 Food & Hospitality and incorporates further opportunity to develop skills in food and beverage service, catering and cookery at Level 3. Students will be introduced to the art of coffee making and food and beverage service incorporating hands-on experience in the food industry. There is also the expectation that students choosing to take this course will show a high level of commitment, energy and resourcefulness in order to complete the year's study.

**Please note students can not take both Food & Hospitality (FAH3) and Food Technology (TEF3).**

## STANDARDS

Standards for this course will be selected from those listed below and are at the discretion of the HOLA  
 Level 2 Standards that contribute to Literacy and Numeracy are indicated by (L) = Literacy; (N) = Numeracy  
 Level 2 & 3 Standards that contribute to UE literacy requirements are indicated by (R) = Reading; (W) = Writing

## VOCATIONAL PATHWAYS

Vocational Pathway information helps with future career planning. Each Standard has been aligned to a potential Pathway, reflected by a tick in the relevant column of the table. "What is your pathway?" Please refer to page 5 in this book or pages 22 and 23 in the Level 1-3 Information Book for more information regarding Vocational Pathways.

STANDARDS						VOCATIONAL PATHWAYS					
Number	Subject Ref	Title	Int/Ext	Credits	CODES	Construction & Infrastructure	Manufacturing & Technology	Primary Industries	Service Industries	Social & Community Services	Creative Industries
<i>NCEA Internal Achievement Standards/Unit Standards</i>											
US17285	Food & Bev	Demonstrate knowledge of espresso coffee equipment and recipes	Internal	4					✓✓		
US17288	Food & Bev	Prepare and present espresso beverages for services	Internal	5					✓✓		
US18497	Cookery	Demonstrate knowledge of culinary products and terms	Internal	8					✓✓		
US13325	Cookery	Prepare and present basic cakes, sponges and scones in a commercial kitchen	Internal	4					✓✓		
<i>Possible Credits Available</i>				21 Credits							



# FOOD TECHNOLOGY (TEF3)

## COURSE INFORMATION

Qualification and level:	NCEA Level 3
Course Prerequisites:	14 credits in NCEA Level 2 Technology or 14 credits in Level 1 Technology or HOLA approval.
Fieldwork:	Nil
Approximate Course Costs:	\$150 basic course ingredients to be supplied, students may also be asked to bring food items). Competition Fee \$35 (optional)
Course Leads to:	Tertiary Study in Technology studies— Technologist /Hospitality /Food Industry
Course Provider/Assessor:	Botany Downs Secondary College
Teacher in charge of subject:	Mrs Thomson
HOLA in charge of subject:	Mr Achary

## COURSE OUTLINE

This course is based on the Technology Curriculum and will be assessed against four Technology Achievement Standards. It provides the opportunity for students to gain up to 20 credits at Level 3. There is no examination; however one Achievement Standard will be assessed through external marking. Students will use a technological approach to develop innovative and creative problem solving skills. Advanced practical skills in a wide range of materials are encouraged along with the learning of techniques and processes. All the standards will be attached to a unit of work on 'Food Innovation'.

**Please note students can not take both Food & Hospitality (FAH3) and Food Technology (TEF3).**

**Please note students can choose only one from of the following Technology options: TEM3, TET3, TEF3.**

**This is a NCEA Level 3 approved subject.**

## STANDARDS

Standards for this course will be selected from those listed below and are at the discretion of the HOLA  
Level 2 Standards that contribute to Literacy and Numeracy are indicated by (L) = Literacy; (N) = Numeracy  
Level 2 & 3 Standards that contribute to UE literacy requirements are indicated by (R) = Reading; (W) = Writing

## VOCATIONAL PATHWAYS

Vocational Pathway information helps with future career planning. Each Standard has been aligned to a potential Pathway, reflected by a tick in the relevant column of the table. "What is your pathway?" Please refer to page 5 in this book or pages 22 and 23 in the Level 1-3 Information Book for more information regarding Vocational Pathways.

STANDARDS						VOCATIONAL PATHWAYS					
Number	Subject Ref	Title	Int/Ext	Credits	CODES	Construction & Infrastructure	Manufacturing & Technology	Primary Industries	Service Industries	Social & Community Services	Creative Industries
<i>NCEA Internal Achievement Standards/Unit Standards</i>											
AS91608	Technology 3.1	Undertake brief development to address an issue within a determined context	Internal	4		✓	✓				✓
AS91611	Technology 3.3	Develop a conceptual design considering fitness for purpose in the broadest sense	Internal	6		✓	✓	✓			✓
AS91643	Technology 3.60	Implement complex procedures to process a specified product	Internal	6			✓	✓	✓		
<i>NCEA External Achievement Standards</i>											
AS91617	Technology 3.10	Undertake a critique of a technological outcome's design.	External	4		✓	✓				
<i>Possible Credits Available</i>			20 Credits								

# FRENCH (FRE3)

## COURSE INFORMATION

Qualification and level:	NCEA Level 3
Course Prerequisites:	Student must sit all the standards and obtain at least 10 credits in NCEA Level 2 French including AS 91121 (reading). An interview might be required at the discretion of the TIC
Fieldwork:	Possible competitions: Alliance Francaise Speaking Competition. \$10 and NZAFT writing competition
Approximate Course Costs:	Course costs \$25 including the yearly subscription to Language Perfect website.
Course Leads to:	Tertiary Study
Course Provider/Assessor:	Botany Downs Secondary College
Teacher in charge of subject:	Mrs Killip
HOLA in charge of subject:	Ms Lodge

## COURSE OUTLINE

*"The more languages you know, the more you are a person " - (Bulgarian proverb)*

This course consolidates students' confidence to express and exchange ideas to establish real communication in French. Students will gain the skills to understand authentic and up to date materials (magazines, movies, internet sites), to express opinions, to retell stories and events, to present facts and arguments to inform, persuade on a range of topics such as a French region of your choice, your future career, current environmental, cultural and social issues. The assessments for Level 3 French consist of a writing portfolio, an interaction portfolio, a reading exam and a listening exam. You will also have the option of attempting the Spoken Presentation Achievement Standard. This is at the discretion of the teacher.

**This is a NCEA Level 3 approved subject.**

## STANDARDS

Standards for this course will be selected from those listed below and are at the discretion of the HOLA  
 Level 2 Standards that contribute to Literacy and Numeracy are indicated by (L) = Literacy; (N) = Numeracy  
 Level 2 & 3 Standards that contribute to UE literacy requirements are indicated by (R) = Reading; (W) = Writing

## VOCATIONAL PATHWAYS

Vocational Pathway information helps with future career planning. Each Standard has been aligned to a potential Pathway, reflected by a tick in the relevant column of the table. "What is your pathway?" Please refer to page 5 in this book or pages 22 and 23 in the Level 1-3 Information Book for more information regarding Vocational Pathways.

STANDARDS						VOCATIONAL PATHWAYS					
Number	Subject Ref	Title	Int/Ext	Credits	CODES	Construction & Infrastructure	Manufacturing & Technology	Primary Industries	Service Industries	Social & Community Services	Creative Industries
<i>NCEA Internal Achievement Standards/Unit Standards</i>											
AS91545	French 3.3	Interact clearly using spoken French to explore and justify varied ideas and perspectives in different situations	Internal	6					✓	✓	✓
AS91547	French 3.5	Write a variety of text types in clear French to explore and justify varied ideas and perspectives	Internal	5					✓		
AS91544	French 3.2	Give a clear spoken presentation in French that communicates a critical response to stimulus material	Internal	3							
<i>NCEA External Achievement Standards</i>											
AS91543	French 3.1	Demonstrate understanding of a variety of extended spoken French texts	External	5					✓		
AS91546	French 3.4	Demonstrate understanding of a variety of extended written/visual French texts	External	5							
<i>Possible Credits Available</i>			24 Credits								

# GEOGRAPHY (GEO3)

## COURSE INFORMATION

Qualification and level:	NCEA Level 3
Course Prerequisites:	12 credits in NCEA Level 2 Geography or Level 2 English (Achievement Standards) or Level 2 History or Level 2 Classical Studies.
Fieldwork:	One day field trip to Muriwai Beach, a three day fieldtrip to Rotorua and a one day field trip within the Auckland Region to carry out research.
Approximate Course Costs:	Fieldwork expenses - \$360 (Rotorua) estimated cost, \$30 (Muriwai) estimated costs, (Auckland) research field trip estimated cost \$20.00
Course Leads to:	Tertiary Study
Course Provider/Assessor:	Botany Downs Secondary College
Teacher in charge of subject:	Miss Brodie
HOLA in charge of subject:	Mr Andrew

## COURSE OUTLINE

Geography is the study of our environment, the way people have changed it to meet their needs and our place in it. Geographers try to understand what makes up the natural and cultural environment and how these elements interact. As geographers, students are encouraged to develop the ability to think about and synthesise material from a range of sources, (including statistics, photographs and aerial imagery, spatial technologies, reports, interviews), then use this material to write their own reports. The transferable skills developed in the study of Geography will be of significant benefit to students intending to study at University. The course will look at the natural processes that shape the Auckland coastal environment, contemporary issues and cultural processes operating at a global and national scale. Carrying out research within the local community will enable students to develop and apply a range of practical skills. There will be a three day field trip to Rotorua. The achievement standards that will be offered for assessment will be *selected* from those listed below and will offer students a total of between 18 and 23 credits. Not all achievement standards listed will be offered.

**This is a NCEA Level 3 approved subject.**

## STANDARDS

Standards for this course will be selected from those listed below and are at the discretion of the HOLA  
 Level 2 Standards that contribute to Literacy and Numeracy are indicated by (L) = Literacy: (N) = Numeracy  
 Level 2 & 3 Standards that contribute to UE literacy requirements are indicated by (R) = Reading: (W) = Writing

## VOCATIONAL PATHWAYS

Vocational Pathway information helps with future career planning. Each Standard has been aligned to a potential Pathway, reflected by a tick in the relevant column of the table. "What is your pathway?" Please refer to page 5 in this book or pages 22 and 23 in the Level 1-3 Information Book for more information regarding Vocational Pathways.

STANDARDS							VOCATIONAL PATHWAYS					
Number	Subject Ref	Title	Int/Ext	Credits	CODES	Construction & Infrastructure	Manufacturing & Technology	Primary Industries	Service Industries	Social & Community Services	Creative Industries	
<i>NCEA Internal Achievement Standards/Unit Standards</i>												
AS91428	Geography 3.3	Analyse a significant contemporary event from a geographic perspective	Internal	3	R				✓			
AS91430	Geography 3.5	Conduct geographic research with consultation	Internal	5					✓			
AS91431	Geography 3.6	Analyse aspects of a contemporary geographic issue	Internal	3	R				✓	✓	✓	
AS91432	Geography 3.7	Analyse aspects of a geographic topic at a global scale	Internal	3				✓	✓		✓	
AS91433	Geography 3.8	Apply spatial analysis, with consultation, to solve a geographic problem	Internal	3				✓	✓			
<i>NCEA External Achievement Standards</i>												
AS91246	Geography 3.1	Demonstrate understanding of how interacting natural processes shape a New Zealand geographic environment	External	4	R/W			✓	✓			
AS91247	Geography 3.2	Demonstrate understanding of how a cultural process shapes geographic environment(s)	External	4	R/W				✓			
AS91429	Geography 3.4	Demonstrate understanding of a given environment(s) through the selection and application of geographic concepts and skills	External	4	R/W	✓		✓	✓			
<i>Possible Credits Available</i>				29 Credits								

# HEALTH EDUCATION (HED3)

## COURSE INFORMATION

Qualification and level:	NCEA Level 3
Course Prerequisites:	10 credits in NCEA Level 2 Health Education—5 credits from 2.1 (external exam) HOLA approval
Fieldwork:	Nil
Approximate Course Costs:	Nil
Course Leads to:	Tertiary Study in the Health Sector
Course Provider/Assessor:	Botany Downs Secondary College
Teacher in charge of subject:	Ms Joyce
HOLA in charge of subject:	Mr Saville

## COURSE OUTLINE

Level 3 Health Education builds on the knowledge that students have gained at Level 2. This course shifts away from personal and interpersonal issues that previous courses have focused on and takes a look at the many societal issues affecting our well-being. During this course students will analyse a health issue that is current in New Zealand's society as well as analysing a current international health issue. Students will research and evaluate a range of health practices currently used in New Zealand to treat particular health conditions. They will also examine the different models of health promotion and their implications for well-being. The course will be made up from the standards below and will be co-constructed with the students at the beginning of the year.

**This is a NCEA Level 3 approved subject.**

## STANDARDS

Standards for this course will be selected from those listed below and are at the discretion of the HOLA  
 Level 2 Standards that contribute to Literacy and Numeracy are indicated by (L) = Literacy; (N) = Numeracy  
 Level 2 & 3 Standards that contribute to UE literacy requirements are indicated by (R) = Reading; (W) = Writing

## VOCATIONAL PATHWAYS

Vocational Pathway information helps with future career planning. Each Standard has been aligned to a potential Pathway, reflected by a tick in the relevant column of the table. "What is your pathway?" Please refer to page 5 in this book or pages 22 and 23 in the Level 1-3 Information Book for more information regarding Vocational Pathways.

STANDARDS						VOCATIONAL PATHWAYS							
Number	Subject Ref	Title	Int/Ext	Credits	CODES	Infrastructure	Construction & Technology	Manufacturing & Industries	Primary Industries	Services Industries	Community Services	Social & Community Services	Creative Industries
<i>NCEA Internal Achievement Standards/Unit Standards</i>													
AS91461	Health 3.1	Analyse a New Zealand health issue	Internal	5	R			✓	✓	✓			
AS91463	Health 3.3	Evaluate health practices currently used in New Zealand	Internal	5	R			✓	✓	✓			
AS91464	Health 3.4	Analyse a contemporary ethical issue in relation to well-being	Internal	4	R			✓	✓	✓			
<i>NCEA External Achievement Standards</i>													
AS91462	Health 3.2	Analyse an international health issue	External	5	R/W			✓	✓	✓			
AS91465	Health 3.5	Evaluate models for health promotion	External	5	R/W			✓		✓			
<i>Possible Credits Available</i>					19-24 Credits								

# HISTORY (HIS3)

## COURSE INFORMATION

Qualification and level:	NCEA Level 3
Course Prerequisites:	12 credits in one of NCEA Level Two Achievement Standards History or Classical Studies or Geography or English (including at least <u>one</u> of AS91233, AS91098, AS91100, or AS91101)
Fieldwork:	Nil
Approximate Course Costs:	Nil
Course Leads to:	Tertiary Study in History or any University research based course
Course Provider/Assessor:	Botany Downs Secondary College
Teacher in charge of subject:	Miss Douglas
HOLA in charge of subject:	Mr Andrew

## COURSE OUTLINE

Level 3 History is the culmination of the course providing a transition to tertiary studies. It demands a higher level of thinking. Through this study students will develop skills in research, interpretation, evaluation, historical empathy and analysis. There is a shift in emphasis towards a consideration of historical method, and historiography – what is involved in the craft of the historian. Students are expected to argue a convincing case in answer to searching historical questions. By the end of the course students will have studied in depth some key historical developments of yesterday's world which will contribute to understanding their society. At Level 3 the themes will possibly include: Aspects of Nineteenth Century New Zealand; the Cold War; a Civilisations topic (aspects of exploration and settlement from 1400-1900); and Historiography.

**This is a NCEA Level 3 approved subject.**

## STANDARDS

Standards for this course will be selected from those listed below and are at the discretion of the HOLA  
 Level 2 Standards that contribute to Literacy and Numeracy are indicated by (L) = Literacy: (N) = Numeracy  
 Level 2 & 3 Standards that contribute to UE literacy requirements are indicated by (R) = Reading: (W) = Writing

## VOCATIONAL PATHWAYS

Vocational Pathway information helps with future career planning. Each Standard has been aligned to a potential Pathway, reflected by a tick in the relevant column of the table. "What is your pathway?" Please refer to page 5 in this book or pages 22 and 23 in the Level 1-3 Information Book for more information regarding Vocational Pathways.

STANDARDS						VOCATIONAL PATHWAYS					
Number	Subject Ref	Title	Int/Ext	Credits	CODES	Construction & Infrastructure	Manufacturing & Technology	Primary Industries	Service Industries	Social & Community Services	Creative Industries
<i>NCEA Internal Achievement Standards/Unit Standards</i>											
AS91434	History 3.1	Research an historical event or place of significance to New Zealanders, using primary and secondary sources	Internal	5	R			✓	✓		
AS91437	History 3.4	Analyse different perspectives of a contested event of significance to New Zealanders	Internal	5	R						✓
<i>NCEA External Achievement Standards</i>											
AS91436	History 3.3	Analyse evidence relating to an historical event of significance to New Zealanders	External	4	R/W			✓			
AS91438	History 3.5	Analyse the causes and consequences of a significant historical event	External	6	R/W						
<i>Possible Credits Available</i>				20 Credits							

# JAPANESE (JAP3)

## COURSE INFORMATION

Qualification and level:	NCEA Level 3
Course Prerequisites:	10 credits in NCEA Level 2 Japanese including standard 91136 (Reading)
Fieldwork:	Possible competitions: AUT Speech Competition, Japanese Inter-School Debating Competition
Approximate Course Costs:	Course Costs— \$28.00 including subscription to Education Perfect ; Course book ~ \$35
Course Leads to:	Tertiary Study
Course Provider/Assessor:	Botany Downs Secondary College
Teacher in charge of subject:	Ms Lodge
HOLA in charge of subject:	Ms Lodge

## COURSE OUTLINE

*How many languages you know - that many times you are a person.* (Pavlo Tychyna, Ukrainian proverb)

A practical course that looks at language survival skills and developing fluency in the language so that the students can visit Japan independently in the future if they desire. Topics in focus include: Shopping and Eating Out, Planning a Trip and Travelling in Japan. Year 13 students will also complete a unit on Future Plans and Work which looks at careers where they can use their Japanese. At Year 13, students also have the option of also attempting the Spoken Presentation Achievement Standard. This is at the discretion of the teacher.

**This is a NCEA Level 3 approved subject.**

## STANDARDS

Standards for this course will be selected from those listed below and are at the discretion of the HOLA  
 Level 2 Standards that contribute to Literacy and Numeracy are indicated by (L) = Literacy; (N) = Numeracy  
 Level 2 & 3 Standards that contribute to UE literacy requirements are indicated by (R) = Reading; (W) = Writing

## VOCATIONAL PATHWAYS

Vocational Pathway information helps with future career planning. Each Standard has been aligned to a potential Pathway, reflected by a tick in the relevant column of the table. "What is your pathway?" Please refer to page 5 in this book or pages 22 and 23 in the Level 1-3 Information Book for more information regarding Vocational Pathways.

STANDARDS						VOCATIONAL PATHWAYS					
Number	Subject Ref	Title	Int/Ext	Credits	CODES	Construction & Infrastructure	Manufacturing & Technology	Primary Industries	Service Industries	Social & Community Services	Creative Industries
<i>NCEA Internal Achievement Standards/Unit Standards</i>											
AS91554	Japanese 3.2	Give a clear spoken presentation in Japanese that communicates a critical response to stimulus material.	Internal	3							
AS91555	Japanese 3.3	Interact clearly using spoken Japanese to explore and justify varied ideas and perspectives in different situations	Internal	6					✓	✓	✓
AS91557	Japanese 3.5	Write a variety of text types in clear Japanese to explore and justify varied ideas and perspectives.	Internal	5					✓		
<i>NCEA External Achievement Standards</i>											
AS91553	Japanese 3.1	Demonstrate understanding of a variety of extended spoken Japanese texts.	External	5					✓		
AS91556	Japanese 3.4	Demonstrate understanding of a variety of extended written/visual Japanese texts.	External	5							
				<i>Possible Credits Available</i>		24 Credits					

# MATHEMATICS (MAT3)

## COURSE INFORMATION

Qualification and level:	NCEA Level 3
Course Prerequisites:	At least 14 credits in NCEA Level 2 Mathematics and Statistics including AS91267-Apply Probability methods in solving problems
Fieldwork:	Nil
Approximate Course Costs:	Workbook-\$35, FX9750GII Casio Graphic calculator -approximately \$120 is compulsory
Course Leads to:	University Entrance
Course Provider/Assessor:	Botany Downs Secondary College
Teacher in charge of subject:	Ms Bennet
HOLA in charge of subject:	Ms Bennet

## COURSE OUTLINE

Level 3 Mathematics is for students who wish to continue studying Mathematics at level 3 to gain university entrance or for other future employment.

This course will assess six Level 3 achievement standards from the Calculus and Statistics standards giving a total of 22 credits. This course will cover themes related to operations research, optimisation and data analysis. These standards have been selected because they develop skills that would appropriate in a wide range of tertiary courses and future careers.

**This is a NCEA Level 3 approved subject.**

## STANDARDS

Standards for this course will be selected from those listed below and are at the discretion of the HOLA  
 Level 2 Standards that contribute to Literacy and Numeracy are indicated by (L) = Literacy; (N) = Numeracy  
 Level 2 & 3 Standards that contribute to UE literacy requirements are indicated by (R) = Reading; (W) = Writing

## VOCATIONAL PATHWAYS

Vocational Pathway information helps with future career planning. Each Standard has been aligned to a potential Pathway, reflected by a tick in the relevant column of the table. "What is your pathway?" Please refer to page 5 in this book or pages 22 and 23 in the Level 1-3 Information Book for more information regarding Vocational Pathways.

STANDARDS						VOCATIONAL PATHWAYS					
Number	Subject Ref	Title	Int/Ext	Credits	CODES	Construction & Infrastructure	Manufacturing & Technology	Primary Industries	Service Industries	Social & Community Services	Creative Industries
<i>NCEA Internal Achievement Standards/Unit Standards</i>											
91574/Algebra	Maths & Statistics 3.2	Apply linear programming methods in solving problems	Internal	3		✓	✓	✓			
91587/Algebra	Maths & Statistics 3.15	Apply systems of simultaneous equations in solving problems	Internal	3		✓	✓	✓			
91580/Statistics	Maths & Statistics 3.8	Investigate time series data	Internal	4				✓		✓	
91581/Statistics	Maths & Statistics 3.10	Investigate bivariate measurement data	Internal	4				✓			
91575/Trigonometry	Maths & Statistics 3.3	Apply trigonometric methods in solving problems	Internal	4		✓	✓				
91586/Probability	Maths & Statistics 3.14	Apply probability distributions in solving problems	External	4	N			✓	✓	✓	
<i>Possible Credits Available</i>				22 Credits							



# MICROSOFT OFFICE SPECIALIST (MOS3)

## COURSE INFORMATION

Qualification and level:	NCEA Level 1, 2 or 3 (multi level)
Course Prerequisites:	By application to/recommendation of Whanau Leader or Deputy Principal
Fieldwork:	Nil
Approximate Course Costs:	Nil
Course Leads to:	Vocational pathway in services and/or social and community services
Course Provider/Assessor:	Botany Downs Secondary College
Teacher in charge of subject:	Mr Patchigalla
HOLA in charge of subject:	Mr Achary

## COURSE OUTLINE

Microsoft Office Specialist (MOS) is an international certification of proficiency in the Microsoft Office suite of applications, providing valued skills for employment, using the worlds most popular business suite. BDSC is a certification centre as a Microsoft IT Academy. The course is expected to be self-paced, so that students will master different application using a variety of learning resources and activities (print, e-books, online videos). Ideally, students will complete project-based learning and assessments from other subject areas to develop these skills. The assessment is by online testing within the applications.

Students can gain MOS in Word, Excel, PowerPoint, Outlook, Access, and OneNote. The Microsoft Office Expert in also possible in Word and Excel. A student may be awarded Microsoft Office Master by achieving 4 MOS certificates. In addition, as shown by the table below, MOS and MOE courses can be credited to NCEA in a process called 'credit inclusion' as replacements for Unit Standards, at the end of an academic year. The key advantages of this course is that it is **multi-level** (Years 12-13), **personalised** (choose which applications and how many) **on-line and completed at a student's own pace**.

Entrance to this course is by application to (or invitation from) Whanau Leaders or Senior Leadership Team.

## STANDARDS

Standards for this course will be selected from those listed below and are at the discretion of the HOLA  
 Level 2 Standards that contribute to Literacy and Numeracy are indicated by (L) = Literacy: (N) = Numeracy  
 Level 2 & 3 Standards that contribute to UE literacy requirements are indicated by (R) = Reading: (W) = Writing

## VOCATIONAL PATHWAYS

Vocational Pathway information helps with future career planning. Each Standard has been aligned to a potential Pathway, reflected by a tick in the relevant column of the table. "What is your pathway?" Please refer to page 5 in this book or pages 22 and 23 in the Level 1-3 Information Book for more information regarding Vocational Pathways.

STANDARDS						VOCATIONAL PATHWAYS					
Number	Subject Ref	Title	Int/Ext	Credits	CODES	Infrastructure & Construction	Technology & Manufacturing	Primary Industries	Service Industries	Social & Community Services	Creative Industries
<i>Microsoft Course</i>											
Business Information Processing	US107 & 111 (Level 2)	Microsoft Office Word	Internal	4							
Generic Computing	US2784 (Level 2)	Microsoft Office Excel	Internal	4							
Generic Computing	US25662 (Level 2)	Microsoft Office Outlook	Internal	4							✓
Generic Computing	US5940 (Level 3)	Microsoft Office Powerpoint	Internal	4							✓
Business Information Processing	US2787 (Level 3)	Microsoft Office Access	Internal	5							
Generic Computing	US112 (Level 3)	Microsoft Office Word Expert	Internal	5							
Generic Computing	US2785 (Level 3)	Microsoft Office Excel Expert	Internal	5							
<i>Possible Credits Available</i>			22 Credits								

# MULTI MATERIALS TECHNOLOGY (TEM3)

## COURSE INFORMATION

Qualification and level:	NCEA Level 3
Course Prerequisites:	At least <b>3 out of 4</b> of the Achievement Standards passed at level 2 or 22 credits in Level 1 Multi-Materials Technology or HOLA agreement.
Fieldwork:	Nil
Approximate Course Costs:	\$80
Course Leads to:	Tertiary Study in Technology related studies
Course Provider/Assessor:	Botany Downs Secondary College
Teacher in charge of subject:	Mr Jowers-Wilding
HOLA in charge of subject:	Mr Achary

## COURSE OUTLINE

This course is based on the Technology Curriculum and will be assessed against four Technology Achievement Standards. It provides the opportunity for students to gain up to 20 credits at Level 3. There is no examination; however one Achievement Standard will be assessed through external marking. Students will use a technological approach to develop innovative and creative problem solving skills. Advanced practical skills in a wide range of materials are encouraged along with the learning of techniques and processes. All the standards will be attached to a unit of work on 'Innovation'.

**Please note students can choose only one from of the following Technology options: TEM3, TET3, TEF3.**

**This is a NCEA Level 3 approved subject.**

## STANDARDS

Standards for this course will be selected from those listed below and are at the discretion of the HOLA  
 Level 2 Standards that contribute to Literacy and Numeracy are indicated by (L) = Literacy; (N) = Numeracy  
 Level 2 & 3 Standards that contribute to UE literacy requirements are indicated by (R) = Reading; (W) = Writing

## VOCATIONAL PATHWAYS

Vocational Pathway information helps with future career planning. Each Standard has been aligned to a potential Pathway, reflected by a tick in the relevant column of the table. "What is your pathway?" Please refer to page 5 in this book or pages 22 and 23 in the Level 1-3 Information Book for more information regarding Vocational Pathways.

STANDARDS						VOCATIONAL PATHWAYS					
Number	Subject Ref	Title	Int/Ext	Credits	CODES	Construction & Infrastructure	Manufacturing & Technology	Primary Industries	Service Industries	Social & Community Services	Creative Industries
<i>NCEA Internal Achievement Standards/Unit Standards</i>											
AS91608	Technology 3.1	Undertake brief development to address an issue within a determined context	Internal	4		✓	✓				✓
AS91611	Technology 3.4	Develop a prototype considering fitness for purpose in the broadest sense	Internal	6		✓	✓	✓			✓
AS91620	Technology 3.20	Implement complex procedures to integrate parts using resistant materials to make a specified product	Internal	6		✓	✓				✓
<i>NCEA External Achievement Standards</i>											
AS91617	Technology 3.10	Undertake a critique of a technological outcome's design	External	4		✓	✓	✓			
<i>Possible Credits Available</i>			20 Credits								

# MEDIA STUDIES (MED3)

## COURSE INFORMATION

Qualification and level:	NCEA Level 3
Course Prerequisites:	14 Credits at Level 2 Media Studies or at TIC discretion (Strong English or History grades an advantage for students new to the subject).
Fieldwork:	Field trip to either a media industry, tertiary institution or a film viewing
Approximate Course Costs:	Anywhere between \$20-50 approximately. (tbc) Students are expected to pay for all trips taken and film screenings at the end of the year. Each trip planned may have different costs.
Course Leads to:	Tertiary Study
Course Provider/Assessor:	Botany Downs Secondary College
Teacher in charge of subject:	Mr Greenstreet
HOLA in charge of subject:	Ms Logan

## COURSE OUTLINE

In Level 3 Media Studies students will develop their skills of analysis and focus on close reading of current affairs, research of media issues, and a genre study of Science Fiction. Students will be introduced to a range of new theoretical approaches that will prepare them for any further tertiary study and enable them to approach the subject in a thorough, critical fashion. The practical component of the course will cover a major documentary production using a range of technologies and narrative approaches. It is mandatory that students have successfully completed Media Studies at Level 2. Scholarship Media Studies is also available to all students, which builds on the skills and theoretical approaches developed over all 3 years of senior Media Studies. Students are strongly encouraged to bring their own devices like laptops, cameras and earphones to enable a smoother learning process.

**This is a NCEA Level 3 approved subject.**

## STANDARDS

Standards for this course will be selected from those listed below and are at the discretion of the HOLA  
Level 2 Standards that contribute to Literacy and Numeracy are indicated by (L) = Literacy; (N) = Numeracy  
Level 2 & 3 Standards that contribute to UE literacy requirements are indicated by (R) = Reading; (W) = Writing

## VOCATIONAL PATHWAYS

Vocational Pathway information helps with future career planning. Each Standard has been aligned to a potential Pathway, reflected by a tick in the relevant column of the table. "What is your pathway?" Please refer to page 5 in this book or pages 22 and 23 in the Level 1-3 Information Book for more information regarding Vocational Pathways.

STANDARDS						VOCATIONAL PATHWAYS					
Number	Subject Ref	Title	Int/Ext	Credits	CODES	Construction & Infrastructure	Manufacturing & Technology	Primary Industries	Service Industries	Social & Community Services	Creative Industries
<i>NCEA Internal Achievement Standards/Unit Standards</i>											
AS91491	Media Studies 3.2	Demonstrate understanding of the meaning of a media text through different readings	Internal	3							✓
AS91494	Media Studies 3.5	Produce a design for a media product that meet s the requirements of a brief	Internal	4							✓
AS91495	Media Studies 3.6	Produce a media product to meet the requirements of a brief	Internal	6							✓
AS91496	Media studies 3.7	Demonstrate understanding of a significant development in the media	Internal	3					✓	✓	
<i>NCEA External Achievement Standards</i>											
AS91493	Media Studies 3.4	Demonstrate understanding of a relationship between a media genre and society	External	4	R/W						✓
<i>Possible Credits Available</i>				20 Credits							

# MUSIC PRACTICAL (MUP3)

## COURSE INFORMATION

Qualification and level:	NCEA Level 3
Course Prerequisites:	10 credits in NCEA Level 2 Music or at the discretion of HOLA. The ability to read music and play an instrument is essential for those who intend to do NCEA Level 3 Practical Music
Fieldwork:	Attendance at concerts which relate and support the student's focus of study. Possible attendance at composition workshop
Approximate Course Costs:	Accompanist for solo performances \$100 (approximate and optional)
Course Leads to:	Tertiary Study in Music and Performing Arts Courses
Course Provider/Assessor:	Botany Downs Secondary College
Teacher in charge of subject:	Ms Treneman
HOLA in charge of subject:	Ms Treneman

## COURSE OUTLINE

This course builds on the experiences of Level 2 Music and will prepare students for study at tertiary level. The course focuses on the composition and performance of music. While composing and performing, students are actively listening and developing aural sensitivity. The students will be given the opportunity to present performances as both a featured soloist and as a member of a group, and compose a variety of pieces of music which demonstrate a range of technical and creative skills. This course will suit the student who enjoys performing and composing music. Students must play an instrument and should be learning either through the Itinerant music scheme or privately. Please be aware that the performance Achievement Standards will be assessed during evening concerts open to the school community.

**This is a NCEA Level 3 approved subject.**

## STANDARDS

Standards for this course will be selected from those listed below and are at the discretion of the HOLA  
 Level 2 Standards that contribute to Literacy and Numeracy are indicated by (L) = Literacy; (N) = Numeracy  
 Level 2 & 3 Standards that contribute to UE literacy requirements are indicated by (R) = Reading; (W) = Writing

## VOCATIONAL PATHWAYS

Vocational Pathway information helps with future career planning. Each Standard has been aligned to a potential Pathway, reflected by a tick in the relevant column of the table. "What is your pathway?" Please refer to page 5 in this book or pages 22 and 23 in the Level 1-3 Information Book for more information regarding Vocational Pathways.

STANDARDS						VOCATIONAL PATHWAYS					
Number	Subject Ref	Title	Int/Ext	Credits	CODES	Construction & Infrastructure	Manufacturing & Technology	Primary Industries	Service Industries	Social & Community Services	Creative Industries
<i>NCEA Internal Achievement Standards/Unit Standards</i>											
AS91416	Music 3.1	Perform two programmes of music as a featured soloist.	Internal	8							✓
AS91417	Music 3.2	Perform a programme of music as a featured soloist on a second instrument.	Internal	4							✓
AS91418	Music 3.3	Demonstrate ensemble skills by performing two substantial pieces as a member of a group	Internal	4							✓
AS91419	Music 3.4	Communicate musical intention by composing three original pieces of music.	Internal	8							✓
AS91424	Music 3.9	Create two arrangements for an ensemble.	Internal	4							✓
<i>NCEA External Achievement Standards</i>											
AS91420	Music 3.5	Integrate aural skills into written representation.	External	4							✓
				<i>Possible Credits Available</i>							
				24 Credits							

# MUSIC STUDIES (MUS3)

## COURSE INFORMATION

Qualification and level:	NCEA Level 3
Course Prerequisites:	10 credits in NCEA Level 2 Music or at the discretion of HOLA. The ability to read music is essential is those who intend to do NCEA Level 3 Music Studies
Fieldwork:	Attendance at concerts which relate to and support the student's focus of study
Approximate Course Costs:	Performances \$30
Course Leads to:	Tertiary Study in Music and Performing Arts Courses
Course Provider/Assessor:	Botany Downs Secondary College
Teacher in charge of subject:	Ms Treneman
HOLA in charge of subject:	Ms Treneman

## COURSE OUTLINE

Level 3 Music Studies builds on the experiences in Level 2 Music and prepares students for entry into tertiary courses. Students will have the opportunity to develop their literacy in music. This involves the development of knowledge and skills relating to styles, genres, technologies, and musical structures. The course focuses on the analysis of music, understanding the way a composition is structured and understanding the background or context of musical works. It also gives students the opportunity to research an area or topic of music of their own choosing.

**This is a NCEA Level 3 approved subject.**

## STANDARDS

Standards for this course will be selected from those listed below and are at the discretion of the HOLA  
 Level 2 Standards that contribute to Literacy and Numeracy are indicated by (L) = Literacy; (N) = Numeracy  
 Level 2 & 3 Standards that contribute to UE literacy requirements are indicated by (R) = Reading; (W) = Writing

## VOCATIONAL PATHWAYS

Vocational Pathway information helps with future career planning. Each Standard has been aligned to a potential Pathway, reflected by a tick in the relevant column of the table. "What is your pathway?" Please refer to page 5 in this book or pages 22 and 23 in the Level 1-3 Information Book for more information regarding Vocational Pathways.

STANDARDS						VOCATIONAL PATHWAYS					
Number	Subject Ref	Title	Int/Ext	Credits	CODES	Construction & Infrastructure	Manufacturing & Technology	Primary Industries	Service Industries	Social & Community Services	Creative Industries
<i>NCEA Internal Achievement Standards/Unit Standards</i>											
AS91422	Music 3.7	Analyse a substantial music work	Internal	4		✓					✓
AS91424	Music 3.9	Create two arrangements for an ensemble	Internal	4		✓					✓
AS91425	Music 3.10	Research a music topic	Internal	6		✓					✓
<i>NCEA External Achievement Standards</i>											
AS91421	Music 3.6	Demonstrate an understanding of harmonic and tonal conventions in a range of music scores	External	4		✓					✓
AS91423	Music 3.8	Examine the influence of context on a substantial music work	External	4		✓					✓
				<i>Possible Credits Available</i>		22 Credits					

# OUTDOOR EDUCATION (OED3)

## COURSE INFORMATION

Qualification and level:	NCEA Level 3
Course Prerequisites:	OED2
Fieldwork:	3 day surfing camp at Raglan, 4 day sailing trip aboard Steinlager II, 3 day leadership camp in Hunua, 4 day snow trip and climbing camp, 3 day Hunua bush survival trip. 2 day white water Kayaking trip
Approximate Course Costs:	
Course Leads to:	University, Sport and recreation courses, Adventure Tourism, Recreation
Course Provider/Assessor:	Botany Downs Secondary College
Teacher in charge of subject:	Mr Williams
HOLA in charge of subject:	Mr Saville

## COURSE OUTLINE

Level 3 Outdoor Education starts with 2 surf sessions to prepare and assess risks involved in outdoor education followed by a 3 day surf camp in Raglan. The next unit looks at the benefits that outdoor education has on our overall wellbeing and focuses around personal development during a 4 day sailing trip around Great Barrier Island. Students also experience what it takes to be an effective leader while planning and facilitating a 3 day camp at Kokako Lodge for the Level 1 OED students. We also do Mountaineering and Snowsports camp in Central North Island focussing on how to safely climb Mt Ruapehu, snow survival skills and Snowboarding. All trips in this course are compulsory as they are attached with assessments. This course is full Achievement Standard based and the majority of time is spent completing the theoretical aspects during class time.

**Please note if you are also taking PED3 in Year 13 you may be required to take one different achievement standard due to clashes of credits.**

## STANDARDS

Standards for this course will be selected from those listed below and are at the discretion of the HOLA  
 Level 2 Standards that contribute to Literacy and Numeracy are indicated by (L) = Literacy; (N) = Numeracy  
 Level 2 & 3 Standards that contribute to UE literacy requirements are indicated by (R) = Reading; (W) = Writing

## VOCATIONAL PATHWAYS

Vocational Pathway information helps with future career planning. Each Standard has been aligned to a potential Pathway, reflected by a tick in the relevant column of the table. "What is your pathway?" Please refer to page 5 in this book or pages 22 and 23 in the Level 1-3 Information Book for more information regarding Vocational Pathways.

STANDARDS						VOCATIONAL PATHWAYS					
Number	Subject Ref	Title	Int/Ext	Credits	CODES	Construction & Infrastructure	Manufacturing & Technology	Primary Industries	Service Industries	Social & Community Services	Creative Industries
<i>NCEA Internal Achievement Standards/Unit Standards</i>											
20121	Outdoor Recreation	Demonstrate kayaking skills on grade II white water	Internal	4				✓	✓	✓	
476	Outdoor Recreation	Roll a kayak	Internal	2					✓	✓	
91498	Physical Ed 3.1	Evaluate physical activity experiences to devise strategies for lifelong wellbeing	Internal	4	L			✓	✓	✓	
91501	Physical Ed 3.4	Demonstrate quality performance of a physical activity in an applied setting	Internal	4					✓	✓	
91502	Physical Ed 3.5	Examine a current physical activity event, trend, or issue and its impact on New Zealand	Internal	4	L,R			✓	✓	✓	
91504	Physical Ed 3.7	Analyse issues in safety management for outdoor activity to devise safety management	Internal	3	L						
91505	Physical Ed 3.8	Examine contemporary leadership principles applied in physical activity contexts	Internal	4	L,R				✓	✓	
				<i>Possible Credits Available</i>		25 Credits					

# PHYSICAL EDUCATION (PED3)

## COURSE INFORMATION

Qualification and level:	NCEA Level 3
Course Prerequisites:	12 credits in NCEA Level 2 Physical Education (should include AS 2.2) or HOLA approval AND shown a high level of effort and commitment in PED2, (you will need to have proven ability in English and Science)
Fieldwork:	Off site fitness and sport training,
Approximate Course Costs:	Some off-site practical work approx. \$100.
Course Leads to:	Tertiary Study and Scholarship
Course Provider/Assessor:	Botany Downs Secondary College
Teacher in charge of subject:	Mr Saville
HOLA in charge of subject:	Mr Saville

## COURSE OUTLINE

Level 3 Physical Education is an exciting course that promotes learning in, through and about movement. The course requires a more in depth study of how the body works and how to train it. In this course we bring together knowledge in sport, sociology and science through the disciplines of human physiology, psychology, biomechanics, evaluating physical activity experiences, health promotion and researching critical issues in physical activity. This course has the potential to further students critical thinking and understanding to lead to exciting career opportunities in fields such (and not limited to) education, health professions, coaching and fitness industries and sport and exercise science. Theory is applied to the practical situations, sports and activities. The contexts in the practical will vary but will include a selection individual and team sports and fitness training.

**Please note: If you are also taking OED3 in Year 13 you may be required to take one different achievement standard due to clashes of credits.**

**This is a NCEA Level 3 approved subject.**

## STANDARDS

Standards for this course will be selected from those listed below and are at the discretion of the HOLA  
 Level 2 Standards that contribute to Literacy and Numeracy are indicated by (L) = Literacy; (N) = Numeracy  
 Level 2 & 3 Standards that contribute to UE literacy requirements are indicated by (R) = Reading; (W) = Writing

## VOCATIONAL PATHWAYS

Vocational Pathway information helps with future career planning. Each Standard has been aligned to a potential Pathway, reflected by a tick in the relevant column of the table. "What is your pathway?" Please refer to page 5 in this book or pages 22 and 23 in the Level 1-3 Information Book for more information regarding Vocational Pathways.

STANDARDS						VOCATIONAL PATHWAYS					
Number	Subject Ref	Title	Int/Ext	Credits	CODES	Construction & Infrastructure	Manufacturing & Technology	Primary Industries	Service Industries	Social & Community Services	Creative Industries
<i>NCEA Internal Achievement Standards/Unit Standards</i>											
AS91498	Physical Ed 3.1	Evaluate physical activity experiences to devise strategies for lifelong well-being	Internal	4					✓	✓	
AS91499	Physical Ed 3.2	Analyse a physical skill performed by self or others	Internal	3					✓	✓	✓
AS91500	Physical Ed 3.3	Evaluate the effectiveness of a performance improvement programme	Internal	4					✓		✓
AS91501	Physical Ed 3.4	Demonstrate quality performance of a physical activity in an applied setting	Internal	4					✓		✓
AS91502	Physical Ed 3.5	Examine a current physical activity, trend, or issue and its impact on New Zealand society	Internal	4	R				✓	✓	
<i>Possible Credits Available</i>				19 Credits							

# PHYSICS (PHY3)

## COURSE INFORMATION

Qualification and level:	NCEA Level 3
Course Prerequisites:	10 credits in NCEA Level 2 Physics including 10 Credits in Level 2 Mathematics (Achievement Standards) Students who do not meet the above prerequisites but who still wish to study Physics at NCEA Level 3 will require the HOD's endorsement.
Fieldwork:	There may be opportunities for careers-oriented visits and/or opportunities to explore real-work physics, e.g. amusement park physics (to be confirmed)
Approximate Course Costs:	\$20.00 (Education perfect online resources)
Course Leads to:	Tertiary Study in Physics or related fields (see Target Group above).
Course Provider/Assessor:	Botany Downs Secondary College
Teacher in charge of subject:	Mr Raj
HOLA in charge of subject:	Mr Kumar

## COURSE OUTLINE

Physics is the study of matter, energy and forces. In Level 3 Physics students develop understanding of physics concepts and principles and their applications. Practical investigations are a vital part of the course and contribute to the internal assessment AS91521. Outstanding students may choose to sit the Physics Scholarship exam at the end of the course. Students are required to carry out calculations using formulae and describe and explain physics concepts. Topics: 1. Experimental Physics; 2. Mechanics (translational, rotational and simple harmonic motion); 3. Waves; 4. Direct Current Electricity and Capacitance; 5. Electromagnetic Induction; 6. Alternating Current; 7. Atomic Spectra; 8 Photoelectric effect; 9. Nuclear Reactions

**This is a NCEA Level 3 approved subject.**

## STANDARDS

Standards for this course will be selected from those listed below and are at the discretion of the HOLA  
Level 2 Standards that contribute to Literacy and Numeracy are indicated by (L) = Literacy; (N) = Numeracy  
Level 2 & 3 Standards that contribute to UE literacy requirements are indicated by (R) = Reading; (W) = Writing

## VOCATIONAL PATHWAYS

Vocational Pathway information helps with future career planning. Each Standard has been aligned to a potential Pathway, reflected by a tick in the relevant column of the table. "What is your pathway?" Please refer to page 5 in this book or pages 22 and 23 in the Level 1-3 Information Book for more information regarding Vocational Pathways.

STANDARDS						VOCATIONAL PATHWAYS					
Number	Subject Ref	Title	Int/Ext	Credits	CODES	Construction & Infrastructure	Manufacturing & Technology	Primary Industries	Service Industries	Social & Community Services	Creative Industries
<i>NCEA Internal Achievement Standards/Unit Standards</i>											
AS91521	Physics 3.1	Carry out a practical investigation to test a physics theory relating two variables in a non-linear relationship	Internal	4		✓	✓			✓	
AS91525	Physics 3.5	Demonstrate understanding of Modern Physics	Internal	3		✓	✓			✓	
<i>NCEA External Achievement Standards</i>											
AS91523	Physics 3.3	Demonstrate understanding of wave systems	External	4		✓	✓	✓		✓	
AS91524	Physics 3.4	Demonstrate understanding of mechanical systems	External	6		✓	✓	✓		✓	
AS91526	Physics 3.6	Demonstrate understanding of electrical systems	External	6		✓	✓	✓		✓	
				<i>Possible Credits Available</i>		23 Credits					



# SPANISH (SPH3)

## COURSE INFORMATION

Qualification and level:	NCEA Level 3
Course Prerequisites:	Students must sit all the standards and obtain at least 10 credits in NCEA Level 2 Spanish. An interview might be required at the discretion of the TIC.
Fieldwork:	Possible competitions: debating and speech competitions
Approximate Course Costs:	Course Costs \$27 including the yearly subscription to Education Perfect website.
Course Leads to:	Tertiary studies
Course Provider/Assessor:	Botany Downs Secondary College
Teacher in charge of subject:	Miss Grall
HOLA in charge of subject:	Ms Lodge

## COURSE OUTLINE

*"One language sets you in a corridor for life. Two languages open every door along the way." Frank Smith*

Level 3 Spanish consolidates students' confidence to express and exchange ideas to establish real communication in Spanish.

Students will gain the skills to understand authentic and up to date materials (magazines, movies, internet sites), to express opinions, to retell stories and events, to present facts and arguments to inform, persuade on a range of topics such as a Spanish speaking country of your choice, your future career, current environmental, cultural and social issues.

The assessments consist of a writing portfolio, an interaction portfolio, a reading exam and a listening exam.

You will also have the option of attempting the Spoken Presentation Achievement Standard. This is at the discretion of the teacher.

**This is a NCEA Level 3 approved subject.**

## STANDARDS

Standards for this course will be selected from those listed below and are at the discretion of the HOLA  
 Level 2 Standards that contribute to Literacy and Numeracy are indicated by (L) = Literacy; (N) = Numeracy  
 Level 2 & 3 Standards that contribute to UE literacy requirements are indicated by (R) = Reading; (W) = Writing

## VOCATIONAL PATHWAYS

Vocational Pathway information helps with future career planning. Each Standard has been aligned to a potential Pathway, reflected by a tick in the relevant column of the table. "What is your pathway?" Please refer to page 5 in this book or pages 22 and 23 in the Level 1-3 Information Book for more information regarding Vocational Pathways.

STANDARDS						VOCATIONAL PATHWAYS					
Number	Subject Ref	Title	Int/Ext	Credits	CODES	Construction & Infrastructure	Manufacturing & Technology	Primary Industries	Service Industries	Social & Community Services	Creative Industries
<i>NCEA Internal Achievement Standards/Unit Standards</i>											
AS91570	Spanish 3.3	Interact clearly using spoken Spanish to explore and justify varied ideas and perspectives in different situations	Internal	6					✓	✓	✓
AS91572	Spanish 3.5	Write a variety of text types in clear Spanish to explore and justify varied ideas and perspectives.	Internal	5					✓		
AS91569	Spanish 3.2	Give a clear spoken presentation in Spanish that communicates a critical response to stimulus material.	Internal	3							
<i>NCEA External Achievement Standards</i>											
AS91568	Spanish 3.1	Demonstrate understanding of a variety of extended spoken Spanish texts.	External	5					✓		
AS91571	Spanish 3.4	Demonstrate understanding of a variety of extended written/visual Spanish texts.	External	5							
<i>Possible Credits Available</i>				24 Credits							

# SPORTS LEADERSHIP (SPL3)

## COURSE INFORMATION

Qualification and level:	NCEA Level 3
Course Prerequisites:	Level 2 PED, 12SPL, Subject to TIC & HOLA approval
Fieldwork:	Primary School visit
Approximate Course Costs:	Approximately \$30
Course Leads to:	Tertiary study
Course Provider/Assessor:	Botany Downs Secondary College
Teacher in charge of subject:	
HOLA in charge of subject:	Mr Saville

## COURSE OUTLINE

Level 3 Sports Leadership promotes learning in, through and about movement and is a progression from Level 2 Sports Leadership. The students will complete a selection of the standards below that range from evaluating training programmes, communication and feedback within a team situation, and evaluate what it means to have lifelong well-being. This course has the potential to further students understanding to lead to exciting career opportunities in fields such (and not limited to) education, health professions, coaching and fitness industries. Theory is applied to the practical situations, sports and activities. The contexts in the practical will vary but will include a selection of activities such as individual and team sports and fitness training.

## STANDARDS

Standards for this course will be selected from those listed below and are at the discretion of the HOLA  
 Level 2 Standards that contribute to Literacy and Numeracy are indicated by (L) = Literacy; (N) = Numeracy  
 Level 2 & 3 Standards that contribute to UE literacy requirements are indicated by (R) = Reading; (W) = Writing

## VOCATIONAL PATHWAYS

Vocational Pathway information helps with future career planning. Each Standard has been aligned to a potential Pathway, reflected by a tick in the relevant column of the table. "What is your pathway?" Please refer to page 5 in this book or pages 22 and 23 in the Level 1-3 Information Book for more information regarding Vocational Pathways.

STANDARDS						VOCATIONAL PATHWAYS					
Number	Subject Ref	Title	Int/Ext	Credits	CODES	Construction & Infrastructure	Manufacturing & Technology	Primary Industries	Service Industries	Social & Community Services	Creative Industries
<i>NCEA Internal Achievement Standards/Unit Standards</i>											
AS91501	Physical Ed 3.4	Demonstrate quality performance of a physical activity in an applied setting.	Internal	4					✓		✓
US 22771	-	Plan a beginner level coaching session for sports participants	Internal	4							
US 22768	-	Conduct and review a beginner level coaching session	Internal	6							
US 7021	-	Demonstrate exercise techniques	Internal	8							
US 21414	-	Plan and run a recreation activity	Internal	4							
US 20673	-	Demonstrate knowledge of injury prevention and risk and injury management in sport or recreation	Internal	4							
<i>Possible Credits Available</i>				30 Credits							

# STATISTICS & PROBABILITY (SAP3)

## COURSE INFORMATION

Qualification and level: NCEA Level 3  
 Course Prerequisites: Merit or better in AS91264, AS91267, AS91261 and one Level 2 English achievement standard.  
 Fieldwork: -  
 Approximate Course Costs: Workbook \$35, FX9750GII Casio Graphic calculator -approximately \$120 is compulsory  
 Stat LC subscription : \$25  
 Scholarship workbook : approximately \$25  
 Course Leads to: This course will lead to University courses in biological sciences, statistics, commerce and any fields where data collection and analysis are important.  
 Course Provider/Assessor: Botany Downs Secondary College  
 Teacher in charge of subject: Ms Bennet  
 HOLA in charge of subject: Ms Bennet

## COURSE OUTLINE

Level 3 Statistics & Probability will assess six Statistics Level 3 achievement standards giving a total of 24 credits. The aims of this course is to extend students' abilities to tackle modelling and problem-solving situations, to provide a first course on probability procedures based on the normal, binomial and Poisson distributions and to develop students' awareness of the usefulness and wide range of applications of statistical investigation and statistical literacy.

**This is a NCEA Level 3 approved subject.**

## STANDARDS

Standards for this course will be selected from those listed below and are at the discretion of the HOLA  
 Level 2 Standards that contribute to Literacy and Numeracy are indicated by (L) = Literacy; (N) = Numeracy  
 Level 2 & 3 Standards that contribute to UE literacy requirements are indicated by (R) = Reading; (W) = Writing

## VOCATIONAL PATHWAYS

Vocational Pathway information helps with future career planning. Each Standard has been aligned to a potential Pathway, reflected by a tick in the relevant column of the table. "What is your pathway?" Please refer to page 5 in this book or pages 22 and 23 in the Level 1-3 Information Book for more information regarding Vocational Pathways.

STANDARDS						VOCATIONAL PATHWAYS					
Number	Subject Ref	Title	Int/Ext	Credits	CODES	Construction & Infrastructure	Manufacturing & Technology	Primary Industries	Service Industries	Social & Community Services	Creative Industries
<i>NCEA Internal Achievement Standards/Unit Standards</i>											
AS91580	Maths & Statistics 3.8	Investigate times series data	Internal	4				✓		✓	
AS91581	Maths & Statistics 3.9	Investigate bivariate measurement data	Internal	4				✓			
AS91582	Maths & Statistics 3.10	Use statistical methods to make a formal inference	Internal	4				✓	✓	✓	✓
<i>NCEA External Achievement Standards</i>											
AS91585	Maths & Statistics 3.13	Apply probability concepts in solving problems	External	4				✓	✓	✓	
AS91586	Maths & Statistics 3.14	Apply probability distributions in solving problems	External	4				✓	✓	✓	
AS91584	Maths & Statistics 3.12	Evaluate statistically based reports	External	4	W			✓	✓	✓	
<i>Possible Credits Available</i>			24 Credits								

# STATISTICS & PROBABILITY ALTERNATIVE (SPA3)

## COURSE INFORMATION

Qualification and level:	NCEA Level 3
Course Prerequisites:	At least 14 credits in NCEA level 2 Mathematics and Statistics including AS91264, AS91267 and AS91265 or one Level 2 English achievement standard.
Fieldwork:	Nil
Approximate Course Costs:	Workbook-\$35, FX9750GII Casio Graphic calculator -approximately \$120 is compulsory Stat LC subscription : \$25
Course Leads to:	This course will lead to University courses in biological sciences, statistics, commerce and any fields where data collection and analysis are important.
Course Provider/Assessor:	Botany Downs Secondary College
Teacher in charge of subject:	Ms Bennet
HOLA in charge of subject:	Ms Bennet

## COURSE OUTLINE

Level 3 Statistics & Probability-Alternative will assess five Statistics Level 3 achievement standards giving a total of 20 credits. The aims of this course is to extend students' abilities to tackle modelling and problem-solving situations, to provide a first course on probability procedures based on the normal, binomial and Poisson distributions and to develop students' awareness of the usefulness and wide range of applications of statistics.

**This is a NCEA Level 3 approved subject.**

## STANDARDS

Standards for this course will be selected from those listed below and are at the discretion of the HOLA  
 Level 2 Standards that contribute to Literacy and Numeracy are indicated by (L) = Literacy; (N) = Numeracy  
 Level 2 & 3 Standards that contribute to UE literacy requirements are indicated by (R) = Reading; (W) = Writing

## VOCATIONAL PATHWAYS

Vocational Pathway information helps with future career planning. Each Standard has been aligned to a potential Pathway, reflected by a tick in the relevant column of the table. "What is your pathway?" Please refer to page 5 in this book or pages 22 and 23 in the Level 1-3 Information Book for more information regarding Vocational Pathways.

STANDARDS						VOCATIONAL PATHWAYS					
Number	Subject Ref	Title	Int/Ext	Credits	CODES	Construction & Infrastructure	Manufacturing & Technology	Primary Industries	Service Industries	Social & Community Services	Creative Industries
<i>NCEA Internal Achievement Standards/Unit Standards</i>											
AS91580	Maths & Statistics 3.8	Investigate times series data	Internal	4				✓		✓	
AS91581	Maths & Statistics 3.9	Investigate bivariate measurement data	Internal	4				✓			
AS91582	Maths & Statistics 3.10	Use statistical methods to make a formal inference	Internal	4				✓	✓	✓	✓
<i>NCEA External Achievement Standards</i>											
AS91585	Maths & Statistics 3.13	Apply probability concepts in solving problems	External	4				✓	✓	✓	
AS91586	Maths & Statistics 3.14	Apply probability distributions in solving problems	External	4				✓	✓	✓	
<i>Possible Credits Available</i>			20 Credits								

# TEXTILES TECHNOLOGY (TET3)

## COURSE INFORMATION

Qualification and level:	NCEA Level 3
Course Prerequisites:	12 credits in NCEA Level 2 Technology or 20 credits in Level 1 Technology
Fieldwork:	Students may have on-going field work to confer with their client (if they choose to produce a garment for someone other than themselves). Trip to fabric retailers to research fabric and trim options for the major project. Opportunity to experience WOW and the costume department of the Royal New Zealand Ballet in Wellington. Approximate cost: \$350 if undertaken. Visit to a fashion design company based in Auckland.
Approximate Course Costs:	\$40 to cover class materials and a sewing kit. Students are to supply their own fabric and pattern for garment production.
Course Leads to:	Tertiary Study in Design and technology related studies
Course Provider/Assessor:	Botany Downs Secondary College
Teacher in charge of subject:	Ms Lynskey
HOLA in charge of subject:	Mr Achary

## COURSE OUTLINE

Level 3 Textiles Technology focuses on refining the creative and technical skills required to pursue a career in the fashion or textiles industries. It provides the opportunity for students to gain 20 credits at Level 3. Students will build a portfolio of work using a technological approach to develop innovative and creative problem solving skills. A key feature of the main project for Level 3 is to choose an authentic context and issue to work with. Depending on the student's personal interest, a context could be chosen with a need in a variety of areas within the textiles industry, such as; fashion, theatre, or interior design. Students are encouraged to meet designers to gain an understanding of this process within the real world. Use of a wide range of practical skills is encouraged to reinforce and further develop their learning. Students who partake in this course will be preparing themselves for tertiary study in fashion, costume or interior design or to pursue a career in the textiles industry. The second project is a short unit of work where student will aesthetically enhance a chosen product through the use of applied design techniques.

**Please note students can choose only one from of the following Technology options: TEM3, TET3, TEF3.**

**This is a NCEA Level 3 approved subject.**

## STANDARDS

Standards for this course will be selected from those listed below and are at the discretion of the HOLA  
Level 2 Standards that contribute to Literacy and Numeracy are indicated by (L) = Literacy: (N) = Numeracy  
Level 2 & 3 Standards that contribute to UE literacy requirements are indicated by (R) = Reading: (W) = Writing

## VOCATIONAL PATHWAYS

Vocational Pathway information helps with future career planning. Each Standard has been aligned to a potential Pathway, reflected by a tick in the relevant column of the table. "What is your pathway?" Please refer to page 5 in this book or pages 22 and 23 in the Level 1-3 Information Book for more information regarding Vocational Pathways.

STANDARDS							VOCATIONAL PATHWAYS					
Number	Subject Ref	Title	Int/Ext	Credits	CODES	Construction & Infrastructure	Manufacturing & Technology	Primary Industries	Service Industries	Social & Community Services	Creative Industries	
<i>NCEA Internal Achievement Standards/Unit Standards</i>												
AS91623	Technology 3.23	Implement complex procedures to create an applied design for a specified product	Internal	4		✓	✓				✓	
AS91610	Technology 3.3	Develop a conceptual design considering fitness for purpose in the broadest sense	Internal	6	L	✓	✓	✓			✓	
AS91621	Technology 3.21	Implement complex procedures using textile materials to make a specified product	Internal	6		✓	✓				✓	
<i>NCEA External Achievement Standards</i>												
Optional 91617	Technology 3.10	Undertake a critique of a technological outcome's design	External	4		✓	✓	✓				
				<i>Possible Credits Available</i>		20 Credits						

# TRAVEL & TOURISM (TSM3)

## COURSE INFORMATION

Qualification and level:	NCEA Level 3
Course Prerequisites:	60 credits at Level 2, Literacy at Level 2 (5 reading/5 writing). Students who do not meet the prerequisites may make an application for this course.
Fieldwork:	Field trip to be advised
Approximate Course Costs:	\$70
Course Leads to:	Tertiary Study in Travel and Tourism Programmes
Course Provider/Assessor:	Botany Downs Secondary College, Travel Careers & Training
Teacher in charge of subject:	Mrs Brook
HOLA in charge of subject:	Mr Andrew

## COURSE OUTLINE

Level 3 Travel and Tourism is a vocational subject, students achieve unit standards which allow them to work towards study at tertiary level. Travel and Tourism is one of New Zealand's fastest growing industries, the school recognises this fact and the Level 3 course provides interested students with a foot in the door. In this course students will examine the New Zealand Tourism industry and aspects of regional tourism. Students will identify tourist destinations, key geographical features, attractions and activities in Australia. They will describe travel information that would assist tourists visiting Australia. Students will identify tourist destinations, key geographical features, attractions and activities in the Pacific Islands. They will describe travel information that would assist tourists visiting Pacific Islands.

## STANDARDS

Standards for this course will be selected from those listed below and are at the discretion of the HOLA  
 Level 2 Standards that contribute to Literacy and Numeracy are indicated by (L) = Literacy; (N) = Numeracy  
 Level 2 & 3 Standards that contribute to UE literacy requirements are indicated by (R) = Reading; (W) = Writing

## VOCATIONAL PATHWAYS

Vocational Pathway information helps with future career planning. Each Standard has been aligned to a potential Pathway, reflected by a tick in the relevant column of the table. "What is your pathway?" Please refer to page 5 in this book or pages 22 and 23 in the Level 1-3 Information Book for more information regarding Vocational Pathways.

STANDARDS						VOCATIONAL PATHWAYS					
Number	Subject Ref	Title	Int/Ext	Credits	CODES	Construction & Infrastructure	Manufacturing & Technology	Primary Industries	Service Industries	Social & Community Services	Creative Industries
<i>NCEA Internal Achievement Standards/Unit Standards</i>											
US18211	-	Demonstrate knowledge of Australia as a tourist destination	Internal	8							
US3727	-	Demonstrate knowledge of the Pacific Islands as a tourist destination	Internal	8							
US18228	-	Provide information about specific regions in New Zealand as tourist destinations	Internal	8							
<i>Possible Credits Available</i>				24 Credits							

# VISUAL ART - DESIGN (DES3)

## COURSE INFORMATION

Qualification and level:	NCEA Level 3
Course Prerequisites:	16 credits in NCEA Level 2 Art Design or HOD approval
Fieldwork:	Field trip and costs are yet to be confirmed
Approximate Course Costs:	\$70 including final folio board printing
Course Leads to:	Tertiary Study in Design fields.
Course Provider/Assessor:	Botany Downs Secondary College
Teacher in charge of subject:	Ms Cunningham
HOLA in charge of subject:	Ms Clapperton

## COURSE OUTLINE

Design is within the Visual Art Department. Design is a discipline. If done well, it facilitates this exchange by presenting new ideas, products and services in a way that draws the viewer in and communicates information clearly and concisely, with as little effort on the part of the viewer as possible. Design is the architecture of information and designers work in almost every vocation in the modern world. Level 3 Design provides an introduction to the necessary skills and tools for students considering a career in any design based field. This course will cover a variety of media and software applications in order to give a broad base of knowledge. Specifically students will have an introduction to illustration, typography, identity design, image manipulation, advertising and animation in a variety of media. Leading design software such as Illustrator, InDesign and Photoshop CC will help students to collate and present their ideas into a final outcome. This is an exciting course that will help students focus on the best of traditional art and computer-aided design into one discipline. Students will have the freedom to explore a topic or theme of their choice for their folio board assessment and the media they choose to present this in. Students must be able to use a computer confidently. Students must purchase a copy of Adobe Photoshop CS6 or higher for their home computers. Recommended Adobe CC suite which is purchased offline for a monthly fee from Adobe. Information on purchasing the required programmes can be found at <https://creative.adobe.com/en/plans?plan=edu> at AUS\$14.99/month (current special for students/teachers) for multiple programmes. Adobe normally have special deals at the beginning of the year for students, so it may end up cheaper than this.

**Students who did not take Level 2 Design will need to submit a portfolio application to be considered for this course. Applications can be obtained from Miss Clapperton (HOD of Art).**

**Please note students can only take a maximum of two subjects from Visual Art: Painting, Photography or Design at Year 13, and are warned against taking 2 Art subjects and another 3rd large internal subject.**

This is a NCEA Level 3 approved subject.

## STANDARDS

Standards for this course will be selected from those listed below and are at the discretion of the HOLA  
 Level 2 Standards that contribute to Literacy and Numeracy are indicated by (L) = Literacy; (N) = Numeracy  
 Level 2 & 3 Standards that contribute to UE literacy requirements are indicated by (R) = Reading; (W) = Writing

## VOCATIONAL PATHWAYS

Vocational Pathway information helps with future career planning. Each Standard has been aligned to a potential Pathway, reflected by a tick in the relevant column of the table. "What is your pathway?" Please refer to page 5 in this book or pages 22 and 23 in the Level 1-3 Information Book for more information regarding Vocational Pathways.

STANDARDS						VOCATIONAL PATHWAYS					
Number	Subject Ref	Title	Int/Ext	Credits	CODES	Construction & Infrastructure	Manufacturing & Technology	Primary Industries	Service Industries	Social & Community Services	Creative Industries
<i>NCEA Internal Achievement Standards/Unit Standards</i>											
AS91445	Design 3.2	Use drawing to demonstrate understanding of conventions appropriate to design.	Internal	4							✓
AS91460	Design 3.5	Produce a resolved work that demonstrates purposeful control of skills appropriate to a visual arts cultural context.	Internal	4							✓
<i>NCEA External Achievement Standards</i>											
AS91455	Design 3.4	Produce a systematic body of work that integrates conventions and regenerates ideas within design practice	External	14							✓
<i>Possible Credits Available</i>				22 Credits							

# VISUAL ART - PAINTING (ART3)

## COURSE INFORMATION

Qualification and level:	NCEA Level 3
Course Prerequisites:	12 credits in NCEA Level 2 Visual Art or HOD approval
Fieldwork:	Top Art Exhibition
Approximate Course Costs:	\$10
Course Leads to:	Tertiary Study in Fine Arts
Course Provider/Assessor:	Botany Downs Secondary College
Teacher in charge of subject:	Mr Clark
HOLA in charge of subject:	Ms Clapperton

## COURSE OUTLINE

Students will choose either Printmaking or Painting for their studies. They will engage in an in-depth study of either of these two disciplines. The course allows each student to follow an individual pathway in order to produce original work. To meet the requirements of the standards, students need to extend their knowledge of art making methods and ideas within their chosen field. Self, peer, collaborative and teacher assessment will be part of the learning process.

**Students who did not take Level 2 Visual Art will need to submit a portfolio application to be considered for this course. Applications can be obtained from Miss Clapperton (HOD of Art).**

**Note: Students can only take a maximum of two subjects from Visual Art: Painting, Photography or Design at Year 13, and are warned against taking 2 Art subjects and another 3rd large internal subject.**

**This is a NCEA Level 3 approved subject.**

## STANDARDS

Standards for this course will be selected from those listed below and are at the discretion of the HOLA  
 Level 2 Standards that contribute to Literacy and Numeracy are indicated by (L) = Literacy; (N) = Numeracy  
 Level 2 & 3 Standards that contribute to UE literacy requirements are indicated by (R) = Reading; (W) = Writing

## VOCATIONAL PATHWAYS

Vocational Pathway information helps with future career planning. Each Standard has been aligned to a potential Pathway, reflected by a tick in the relevant column of the table. "What is your pathway?" Please refer to page 5 in this book or pages 22 and 23 in the Level 1-3 Information Book for more information regarding Vocational Pathways.

STANDARDS						VOCATIONAL PATHWAYS					
Number	Subject Ref	Title	Int/Ext	Credits	CODES	Construction & Infrastructure	Manufacturing & Technology	Primary Industries	Service Industries	Social & Community Services	Creative Industries
<i>NCEA Internal Achievement Standards/Unit Standards</i>											
AS91441	Visual Art 3.1	Analyse methods and ideas from established painting practice.	Internal	4					✓		✓
AS91446	Visual Art 3.2	Use drawing to demonstrate understanding of conventions appropriate to painting sculpture.	Internal	4							✓
AS91451	Visual Art 3.3	Systematically clarify ideas using drawing informed by established painting practice.	Internal	4							✓
<i>NCEA External Achievement Standards</i>											
AS91456	Visual Art 3.4	Produce a systematic body of work that integrates conventions and regenerates ideas within painting practice.	External	14							✓
<i>Possible Credits Available</i>			24 Credits								



# VISUAL ART - PHOTOGRAPHY (PHO3)

## COURSE INFORMATION

Qualification and level:	NCEA Level 3
Course Prerequisites:	16 credits in Level 2 Photography or very successful Level 2 Visual Art /Design (portfolio application and HOD approval)
Fieldwork:	Top Art Exhibition
Approximate Course Costs:	\$60 including final folio board printing
Course Leads to:	Tertiary Study
Course Provider/Assessor:	Botany Downs Secondary College
Teacher in charge of subject:	Ms Clapperton
HOLA in charge of subject:	Ms Clapperton

## COURSE OUTLINE

In Level 3 Photography students will continue studying Digital Photography and its many uses in today and tomorrow's technological world. Level 3 Photography builds on the Level 2 Photography work but requires a greater depth of analysis and justification of photographic methods. Presentation is also expected to be of a much higher standard. Using Photoshop, understanding file systems, setting up a studio with lights, planning, taking and creating digitised images are some of the practical skills that will be enhanced during this course. There is no external examination, students will complete 3 projects throughout the year contributing to the required Standards. Students are to have their own good quality digital camera (at least 7MP with manual features; Aperture and Shutter Speed), a storage device to transfer files to and from home (4 or 8 GB USB recommended) and have purchased a copy of Adobe Photoshop CC for their home computers. Recommended Adobe CC suite which is purchased offline for a monthly fee from Adobe. Information on purchasing the required programmes can be found at <https://creative.adobe.com/en/plans?plan=edu> at AUS\$14.99/month (current special for students/teachers) for multiple programmes. Or Adobe Photoshop (single program) at AUS\$9.99/month. Adobe normally have special deals at the beginning of the year for students, so it may end up cheaper than this.

**Note: this is an artistic subject. Students must be creative and must be ICT literate and be very confident with using a computer.**

**Students who did not take Level 2 Photography will need to submit a portfolio application to be considered for this course. Applications can be obtained from Miss Clapperton (HOD of Art).**

**Please note students can only take a maximum of two subjects from Visual Art: Painting, Photography or Design at Level 3, and are warned against taking 2 Art subjects and another 3rd large internal subject.**

This is a NCEA Level 3 approved subject.

## STANDARDS

Standards for this course will be selected from those listed below and are at the discretion of the HOLA  
 Level 2 Standards that contribute to Literacy and Numeracy are indicated by (L) = Literacy; (N) = Numeracy  
 Level 2 & 3 Standards that contribute to UE literacy requirements are indicated by (R) = Reading; (W) = Writing

## VOCATIONAL PATHWAYS

Vocational Pathway information helps with future career planning. Each Standard has been aligned to a potential Pathway, reflected by a tick in the relevant column of the table. "What is your pathway?" Please refer to page 5 in this book or pages 22 and 23 in the Level 1-3 Information Book for more information regarding Vocational Pathways.

STANDARDS						VOCATIONAL PATHWAYS					
Number	Subject Ref	Title	Int/Ext	Credits	CODES	Construction & Infrastructure	Manufacturing & Technology	Primary Industries	Service Industries	Social & Community Services	Creative Industries
<i>NCEA Internal Achievement Standards/Unit Standards</i>											
AS91447	Photography 3.2	Use drawing to demonstrate understanding of conventions appropriate to photography.	Internal	4							✓
AS91452	Photography 3.3	Systematically clarify ideas using drawing informed by established photography practice.	Internal	4							✓
<i>NCEA External Achievement Standards</i>											
AS91457	Photography 3.4	Produce a systematic body of work that integrates conventions and regenerates ideas within photography practice.	External	14							✓
<i>Possible Credits Available</i>			20 Credits								