



# YEAR 10 OPTION BOOK 2027

BOTANY DOWNS Secondary College

# CONTENTS

## Year 10 Compulsory Subjects

4	English (10ENG)	& Health & Physical Education (10HED/10PEC)
5	Mathematics and Statistics (10MAT)	& Mathematics - Accelerated (1MAX)
6	Science (10SCI)	& Science - Accelerated (1SCX)
7	Social Studies (10SOS)	& English as an Additional Language (10EAC/10ELC)

## Year 10 Optional Subjects

8	Ancient Civilisations (10ANC)	& Art (10ART)
9	Business Pathways (10BUP)	& Chinese (10CHI)
10	Dance (10DAN)	& Design and Visual Communication (10DVC)
11	Digital Technologies (10DIT)	& Digital Art (10DRT)
12	Drama (10DRA)	& Fashion and Design Technology (10FDN)
13	Food Technology (10TEF)	& French (10FRE)
14	Investigative Geography (10IGO)	& Japanese (10JAP)
15	Te Reo Māori (10MAO)	& Media Studies (10MED)
16	Multi Materials Technology (10TEM)	& Music (10MUS)
17	Outdoor Education (10OED)	& Physical Education (10PED)

# INFORMATION FOR PARENTS AND STUDENTS

1. **FIVE** of the subjects studied in Year 9 continue in Year 10.

These subjects are:

**English**  
**Mathematics**  
**Health and Physical Education**  
**Science**  
**Social Studies**

2. The other subjects studied this year become **optional** in Year 10. Students are required to choose **THREE** option subjects for Year 10. The option courses will be for the whole of the Year 10 school year.

3. Consider carefully these two questions:

- (a) What is the highest level you hope to reach at school?
- (b) What subjects are you likely to take at **that level**?

Then work backwards to the lower levels to choose your Year 10 subjects. Remember that **ability, interest and future usefulness** are important reasons for your choices. All students should read the **2027 Option Information Book**. Familiarise yourself with the prerequisites for the senior subjects that you may wish to study in the future.

All option booklets as well as the Auckland University Undergraduate prospectus can be accessed on Office 365 or the BDSC website.

Many Visual and Performing Art, Technology and Languages courses require students to have taken the course in the previous year. **Students must plan their courses to ensure that they meet all the prerequisites.**

If you are considering future university study then you should become familiar with all university requirements e.g. university entrance, literacy, numeracy, U.E. approved subjects as well as subject requirements for specific courses. Careful planning now will prevent future problems in accessing courses.

4. Although every effort will be made to provide the subjects chosen, no guarantee can be given that **all** will be possible. Because of the need to have classes of a certain size, some students may be asked to change options. If not enough students choose a particular option it may be cancelled.

5. This booklet contains a schedule of proposed subjects at all levels. Choosing a subject in Year 10 does **NOT** commit the student to take it in Year 11.

6. If students require guidance they should seek this as soon as possible from the following people:

Careers Advisor  
Subject teacher

Senior Leadership Team  
Whanau Tutor / Mentor

7. **Students must make their option choices during Week 1 of Term 3. Option selection must be completed online by Monday 27 July (Week 2).** Late selection of options **may** mean that students will not receive their first choice of options.

8. Course contributions listed for each subject include resources, activities and trips that are **highly recommended** as being conducive to optimal student learning. Please refer to each individual course descriptor for the compulsory items required for that course.

9. Year 10 Outdoor Education will run in 2027, **limited to two classes only**. Students must select 10OED in the web portal and submit a signed, dated application to Ms Patel (Head of OED) by the Option Selection deadline. Applications must briefly explain why they want to take the course and understand that being able to swim, ride a bike, and stay at camps overnight is a prerequisite. Final selection will be made in consultation with HPE staff.

10. **Course restrictions:**

- Cannot take both 10DRT (Digital Art) and 10ART (Visual Art)
- Cannot take both 10OED (Outdoor Education) and 10PED (Physical Education)
- May only take a maximum of one from 10TEM, 10FDN and/or 10TEF

# YEAR 10 COMPLUSORY SUBJECTS

## ENGLISH (10ENG/10ENA/10LIT)

### COURSE INFORMATION

Fieldwork:	N/A
Course Contributions:	N/A
Course Leads to:	Level 1 English (1ENG, 1ENA, 123ENL, 1EAC, 1ELC)
Teacher in charge of subject:	Ms Mears
HOLA in charge of subject:	Ms Servanin

The Botany Downs Secondary College English Learning Area shares the aims of the New Zealand English Curriculum, which wants students to:

- engage with and enjoy language in all its varieties and
- understand, respond to and use oral, written and visual language effectively in a range of contexts.

English for Year 10 students is compulsory and aims to give students every opportunity of working at the appropriate curriculum level while familiarising themselves with fundamental language skills. Students will engage with a range of text types, including poetry, short stories, novels, films, and non-fiction using them to explore and learn about human experiences. Students will also experiment with a range of communication formats throughout the year. Junior students are encouraged to read widely outside of the classroom.

The 10ENG course will also include some preparation for the new Literacy co-requisite assessments, which will be sat in Term 3.

Students requiring extra literacy support will be placed in 10ENA/10LIT, instead of 10ENG, after consultation with the HOLA, HOD Learner Support, the student and their whanau.



## HEALTH & PHYSICAL EDUCATION (10HED & 10PEC)

### COURSE INFORMATION

Fieldwork:	N/A
Course Contributions:	N/A
Course Leads to:	1PED, 1HED, 1OED, 1AWB
Teacher in charge of subject:	Mrs Leidh
HOLA in charge of subject:	Mr Saville

In Year 10 Health and Physical Education, students participate in two lessons of Core Physical Education (PEC) per week, and one lesson of Health Education (HED) per week. Student progress and achievement in Physical Education and Health Education are assessed and reported on separately. In addition to end-of-topic assessments, there is an end-of-year examination that assess the knowledge gained throughout the year. This course is based on Health and Physical Education in the New Zealand Curriculum. It builds on the knowledge and skills developed in Year 9 Health and Physical Education.

In Year 10 Core Physical Education (10PEC):

- Students participate in and learn through a wide variety of practical contexts.
- PE lessons are focused around the themes of social responsibility, biophysical principles (anatomy, biomechanics and exercise physiology) and socio-cultural influences on participation.
- Students will also develop and be assessed on their movement skills throughout these units.

In Year 10 Health Education (10HED):

- Learning is focused around the topics of Keeping Safe (Alcohol and Drug Education), Healthy Relationships (Sexuality Education) and Mind Matters (Mental Health).





# YEAR 10 COMPLUSORY SUBJECTS

## SCIENCE (10SCI)

### COURSE INFORMATION

Fieldwork:	N/A
Course Contributions:	N/A
Course Leads to:	Level 1 Sciences
Teacher in charge of subject:	Mr Jeet
HOLA in charge of subject:	Mr Kumar

Year 10 Science aims to develop students' understanding of the world around them through the application of scientific knowledge and inquiry. The course emphasises critical thinking and the development of key competencies that are essential for all citizens, not solely those pursuing careers in science and technology. In an increasingly complex and technologically driven world, it is vital for students to understand how scientific knowledge is generated, how technology is developed, and the ways in which science and technology influence society and everyday life. The topics studied include diversity, plants forces and motion, chemical reactivity, electricity, and investigation skills.

Year 10 Science is compulsory, building upon what students learned in Year 9 and developing the necessary skills to handle Year 11 Sciences.

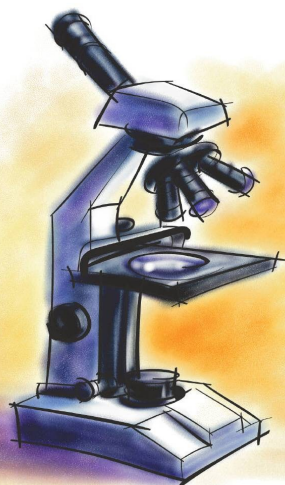

## SCIENCE - ACCELERATED (1SCX)

### COURSE INFORMATION

Fieldwork:	N/A
Course Contributions:	N/A
Course Leads to:	NCEA Level 2: Biology and/or Chemistry
Teacher in charge of subject:	Mrs Devi-Govind/Mrs Singh
HOLA in charge of subject:	Mr Kumar

The Year 10 accelerated class **MUST** take the 1SCX (Biology-Chemistry-1SCB) course while they are in Year 10. The goal is to accelerate their learning, keeping them engaged and motivated in Science subjects.

1SCX course is made up of four standards. The two NCEA externally assessed standards are worth 4 and 5 credits each. The other two standards are BDSC standards that will be assessed internally but will not generate any NCEA credits. The results from these four standards will be used to determine entry into 2BIO and/or 2CHE courses as well as awarding the BDSC Diploma.

#### AS92023: NCEA Externally Assessed Standard (4 credits)

This standard requires students to demonstrate understanding of how physical properties of materials inform their use.

#### AS92022: NCEA Externally Assessed Standard (5 credits)

This standard requires students to demonstrate understanding of genetic variation in relation to an identified characteristic.

#### 1SCX04: School Based Unit

This unit requires students to demonstrate comprehensive understanding of bacteria, fungi and viruses and their effects on our health.

#### 1SCX11: School Based Unit

This unit requires students to demonstrate comprehensive understanding of aspects of chemical reactions including explaining, elaborating, justifying, relating, evaluating, comparing and contrasting, or analysing the classification of reactions. This typically requires the use of chemistry vocabulary, symbols and conventions (including names and formulae), and writing balanced symbol equations.

**Year 11 Science Pathways Following Completion of 1SCX in Year 10:** Students who successfully complete the 1SCX course in Year 10 will have the following options available to them in Year 11 -

1. **Enrol in Level 1 Science (1SCP)**, which serves as a prerequisite for progressing to Level 2 Physics (2PHY).

2. **Select one Level 2 Science subject**, either Biology (2BIO) or Chemistry (2CHE), provided the relevant prerequisite requirements have been met.

3. **Undertake a combination pathway**, consisting of the Level 1 Science course (1SCP) alongside one Level 2 Science subject (2BIO or 2CHE), subject to meeting the prerequisite requirements.

# YEAR 10 COMPLUSORY SUBJECTS

## SOCIAL STUDIES (10SOS)

### COURSE INFORMATION

Fieldwork:	N/A
Course Contributions:	N/A
Course Leads to:	Any Level 1 subject in Social Sciences
Teacher in charge of subject:	Miss Douglas
HOLA in charge of subject:	Miss Douglas

Social Studies education aims to teach students about the world in which they live and how to be informed, critical, active and responsible citizens of that world.

Contexts are drawn from the past, present and future and from places within and beyond New Zealand across Year 9 and 10.

Topics covered in Y10 under the new Curriculum: History, Geography, Civics and Society, and Economic Activity.

These will include an understanding of political literacy and our democratic systems, our rights and responsibilities, and the role of te Tiriti o Waitangi. NZ and Global History will be taught alongside Māori History. Geography will include physical and human processes that shape the world and how people interact with the environment. Economic Activity will include financial and economic systems.

In addition to the content covered, mapping, graphing, interpreting and research skills will be taught and tested. Current events will be covered in class.

At the end of each topic there will be an assessment or a test.



## ENGLISH as an ADDITIONAL LANGUAGE (10EAC/ELC)

### COURSE INFORMATION

Fieldwork:	N/A
Course Contributions:	N/A
Course Leads to:	Level 1 EAC/ELC
Teacher in charge of subject:	Ms Viegas
HOLA in charge of subject:	Ms Servanin

There are TWO courses in the EAL Junior Year 10 programme:

10EAC - ELLP Stage 2-3

10ELC – ELLP Foundation Stage – Stage 1

Students will be placed in the appropriate course. Those needing more support will take 10ELC *instead* of 10ENG. Some students will take 10ELC/10EAC as one of their option subjects.

The course is designed to support students to improve their English proficiency in speaking, listening, reading and writing.

⇒ Comprehensive output:

*Speaking:* conversation, discussion, presentation, enquiry

*Writing:* text structure and genre; syntax (grammar), semantics (meanings), punctuation, spelling

⇒ Comprehensible input:

*Listening:* for specific information, for notetaking, for opinions, intonation

*Reading:* predicting, skimming, and scanning, reading for meaning, inference, genre

Units of work will also include subject specific vocabulary as well as support across the curriculum.



# YEAR 10 OPTIONAL SUBJECTS (choose 3 options)

## ANCIENT CIVILISATIONS (10ANC)

### COURSE INFORMATION

Fieldwork:	N/A
Course Contributions:	Potential art project \$20 (optional)
Course Leads to:	Level 1 History; Level 2 Classical Studies
Teacher in charge of subject:	Miss Douglas
HOLA in charge of subject:	Miss Douglas

This course is designed for all lovers of history who are eager to explore the ancient world. Students will investigate the four major civilisations that helped shape the foundations of Western society: Egypt, Persia, Greece, and Rome. Through engaging lessons and activities, students will discover how these powerful empires rose, how they were governed, and what daily life was like for the people who lived within them. Through fascinating topics such as myth and religion, politics, culture, philosophy, warfare, and even food and burial rituals, students will gain a deeper understanding of the ancient past and its lasting impact on today's world. This course brings history to life, encouraging curiosity, critical thinking, and a sense of discovery. Perfect for anyone who loves history, or wants to see just how exciting it can be.



## ART (10ART)

### COURSE INFORMATION

Fieldwork:	N/A
Course Contributions:	\$40
Course Leads to:	Level 1 Art or Level 1 Digital Art (with HOD approval)
Teacher in charge of subject:	Mrs Baker
HOLA in charge of subject:	Miss Clapperton

The Year 10 Visual Art course will allow students to experience and experiment with a variety of media, techniques and art making tools. Each term there will be a new focus in which students will develop different practical skills such as drawing, painting, sculpture or collage.

Along with practical skills, students will learn how to generate and develop ideas in response to artist models, research, subject matter and cultural influences. Each student completes a painted Skateboard unit which is displayed in the end of year Art Exhibition. Students are able to keep their completed items at the end of the course.

**Note: You cannot take both Visual Art (10ART) and Digital Art (10DRT).**

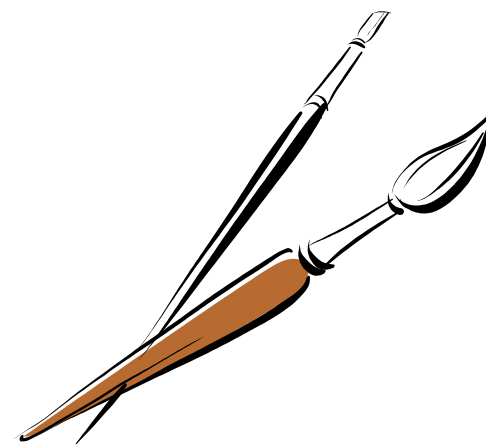

# YEAR 10 OPTIONAL SUBJECTS (choose 3 options)

## BUSINESS PATHWAYS (10BUP)

### COURSE INFORMATION

Fieldwork:	N/A
Course Contributions:	N/A
Course Leads to:	Level 1 Commerce
Teacher in charge of subject:	Mr Sharma
HOLA in charge of subject:	Miss Douglas

This course provides the pathways for Level 1 Commerce and also future business/commerce pathways. Year 10 Business Pathways aims to teach students essential thinking, decision making, investigative, and statistical skills, as they relate to Accounting, Business, Economics, Personal Finance and Innovative thinking. These skills are of primary importance to our young people as New Zealand is a country built on small businesses.

Over the year students will be introduced to the financial language of Accounting, Budgeting, Economics, Marketing, as well as starting a business.

Students who do Year 10 Business Pathways will also take part in the Microsoft Imagine Cup Junior Global Challenge, the Dragons Den competition, and be part of Money week.



## CHINESE (10CHI)

### COURSE INFORMATION

Fieldwork:	Opportunity to go to a Chinese restaurant
Course Contributions:	Workbook \$10 (Highly recommended)
Course Leads to:	Level 1 Chinese
Teacher in charge of subject:	Mrs Kuang
HOLA in charge of subject:	Ms Lodge

Year 10 Chinese focuses on developing the four essential language skills: listening, speaking, reading, and writing. Students will engage with practical and relevant topics such as greetings, family and home life, hobbies, school, daily routines, and food and drink. In addition to language acquisition, students will develop cultural awareness and understanding, by exploring the customs, values, and everyday experiences of Chinese-speaking communities. The course encourages meaningful communication and provides opportunities for students to apply their language skills in real-life contexts. By the end of the course, students will be equipped with a stronger foundation in the Chinese language and a deeper appreciation of Chinese culture, preparing them for further study in Year 11.

This course is designed for **second language learners** and builds on skills developed in Year 9. However, students who did not take Chinese in Year 9 are also welcome to join. The course begins with revision and consolidation of key content to support those who are new to the language. It is aligned with Level 1 NCEA achievement standards, which are intended for students who are acquiring skill in Chinese.

**NOTE:** If you are a heritage speaker of Mandarin (for example, you speak Chinese at home but have had little or no formal education in the language), you must email the Teacher in Charge to arrange a time to assess your language level before choosing this course.



# YEAR 10 OPTIONAL SUBJECTS (choose 3 options)

## DANCE (10DAN)

### COURSE INFORMATION

Fieldwork:	Some optional trips may be offered with costs TBC.
Course Contributions:	N/A
Course Leads to:	Level 1 Dance
Teacher in charge of subject:	Mrs McKenna
HOLA in charge of subject:	Mrs McKenna

This programme is designed to give students an understanding of dance, and is in preparation for Level 1 Dance. Students will learn a variety of dance techniques and choreographic skills. Students are required to attend workshops with dance professionals and work with guest tutors throughout the year. The students will learn a variety of genre's and styles of dance such as: street dance, contemporary, jazz, social and ethnic dance, as well as choreographic techniques to compose dance works.

Students are required to work independently and in groups as well as perform their work on stage, before an audience. Students are to bring PE gear and a water bottle to class as well as their 1B5 dance journal.

It is compulsory for all students to perform in the annual dance showcase, Pulse, in Term 3. It runs for three nights after school. This is when we assess our performance pieces.



## DESIGN & VISUAL COMMUNICATION (10DVC)

### COURSE INFORMATION

Fieldwork:	N/A
Course Contributions:	N/A
Course Leads to:	Level 1 DVC
Teacher in charge of subject:	Mr Jowers-Wilding
HOLA in charge of subject:	Mr Achary

Using drawing, modelling and presentation skills, students develop solutions to a range of challenging design problems. They should ultimately become competent in applying a variety of design and visual communication techniques through graphics practice. This forms the foundation for Level 1 Design and Visual communication course to follow in Year 11.

Design and visual Communication is a portfolio based course with no formal examination.

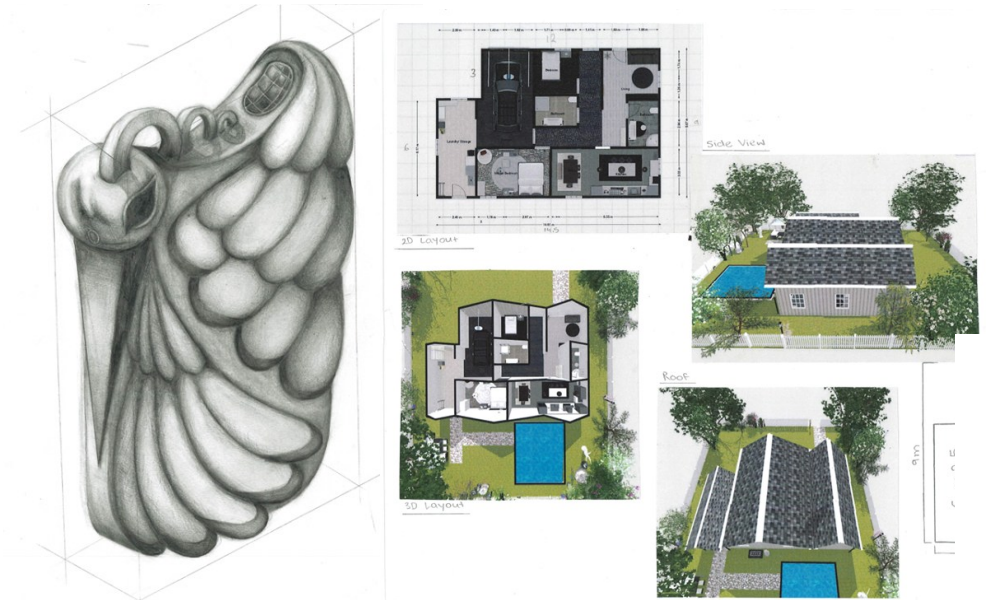

# YEAR 10 OPTIONAL SUBJECTS (choose 3 options)

## DIGITAL TECHNOLOGIES (10DIT)

### COURSE INFORMATION

Fieldwork:	N/A
Course Contributions:	N/A
Course Leads to:	Level 1 DIT
Teacher in charge of subject:	Mrs Nelapati
HOLA in charge of subject:	Mr Achary

Digital Technologies is a taster course for students who might be interested in computer programming, computer science, multimedia, web development and digital infrastructure. This course is suitable for students who are creative, logical and problem-solvers. They move beyond being users and consumers of digital technologies to become creators of new technologies for authentic users. Students will learn computer science concepts like binary, data representation, Minecraft coding and how to program a robot, Micro:bit and the basics for developing websites, multimedia and what is inside a PC. It leads on to Digital Technologies courses in Year 11-12. These classes are going to be held in a normal classroom and students will need to use their own laptops. All students that take this course must commit to providing a laptop that meets BYOD requirements and also to bringing it fully charged to class each lesson.

***It is strongly advised that students who are intending to take Digital Technologies at Level 1, to choose Year 10DIT as an option.***



## DIGITAL ART (10DRT)

### COURSE INFORMATION

Fieldwork:	N/A
Course Contributions:	\$20 (does not include the optional \$10 Adobe licence)
Course Leads to:	Level 1 Digital Art
Teacher in charge of subject:	Mr Hsu
HOLA in charge of subject:	Miss Clapperton

Digital Art focuses on experiencing a variety of digital and practical media, techniques and tools for art-making in the fields of Photography, Digital painting, Design and Illustration. It leads on to Level 1 Digital Art. In future years (Level 2 and 3) Digital Art breaks into separate courses of Photography and Design. Students can take either or both Photography and Design in the senior school.

This course is held in a computer lab which has access to the Adobe suite of programmes. Students can decide to use a laptop for this course but will need it to be high functioning, meet BYOD requirements and be fully charged each lesson.

Laptop students also are required to purchase a copy of Adobe Suite for their laptop. All students are able to purchase a year Adobe licence through the school for approx. \$10. This is handy to install on a home computer for catch up or homework. Information regarding this will be given to students at the beginning of the course.

***Note: you can not take both Visual Art (10ART) and Digital Art (10DRT)***



# YEAR 10 OPTIONAL SUBJECTS (choose 3 options)

## DRAMA (10DRA)

### COURSE INFORMATION

Fieldwork:	N/A
Course Contributions:	\$30 (approximate cost of theatre trips, resources)
Course Leads to:	Level 1 Drama
Teacher in charge of subject:	Mrs Hey
HOLA in charge of subject:	Mrs Hey

Drama in Year 10 is a creative, collaborative, confidence building course and a fun, expressive way to learn and develop knowledge. It leads on to Drama in Year 11.

Taking Drama develops students ability to work with others, think creatively and apply this thinking in practical ways. Students learn to work to deadlines and to present themselves with confidence in a public setting. It encourages leadership skills and offers opportunities to develop communication skills. If you enjoy active learning then Drama is for you.

You will learn about a range of theatrical styles and texts. You will work as performers, directors, designers and creators. You will be given the opportunity to attend a professional drama production.

Drama is a practical course that requires co-operative group work and for you to devise, rehearse, perform and learn lines for scripted work. You will be expected to see a senior/school production in order to review it with a critical eye. You will require a black long sleeved top, black relaxed (track) pants and black lace up canvas shoes to be worn for assessments and any performance opportunities.



## FASHION AND DESIGN TECHNOLOGY (10FDN)

### COURSE INFORMATION

Fieldwork:	N/A
Course Contributions:	\$40
Course Leads to:	Level 1 Fashion and Design Technology
Teacher in charge of subject:	Mrs Thomson
HOLA in charge of subject:	Mr Achary

This course encourages students to gain an appreciation of Technology while developing the creativity and skills to design and manufacture a variety of textile products used in fashion, costume and/or interior design. As well as design illustration skills, students will gain the necessary skills to use and adapt commercial patterns, fit and adjust apparel, create applied designs for fabric using a variety of techniques, as well as accurately use a plain sewer and overlocking sewing machine to sew woven and knit fabrics. The course is intended to provide students with a sound background for senior NCEA Fashion and Design Technology. Course cost covers basic materials for trials and sampling. Students will need to purchase fabric for some of the projects and a commercial pattern for one project.

***You may only select ONE from Multi Materials (10TEM), Fashion & Design Technology (10FDN) and/or Food Technology (10TEF).***



# YEAR 10 OPTIONAL SUBJECTS (choose 3 options)

## FOOD TECHNOLOGY (10TEF)

### COURSE INFORMATION

Fieldwork:	N/A
Course Contributions:	\$90
Course Leads to:	Level 1 Food Technology, Level 1 Food & Hospitality
Teacher in charge of subject:	Mrs Thomson
HOLA in charge of subject:	Mr Achary

This is a practical and theory course progressing on from Year 9 and looks at the exciting and creative facets of food technology, including basic nutrition, product development, safe food handling, bread-making, investigating kitchen machines and being highly creative and original with foods. Those who may be passionate about cooking and designing food products, becoming a chef, or food technologist, while developing culinary skills and will benefit from learning the basics of food development. This is an exciting and dynamic Year 10 programme. It offers a very good introduction to the many opportunities in the food industry, leading onto Food Technology at Level 1, 2 and 3 or Hospitality at Level 1, 2 and 3. There is a weekly practical component where course costs will be charged.

#### Course Contributions:

Basic ingredients will be supplied, however when their ingredient choices are outside the food department's pantry basics list, students will be requested to bring some foods for practical lessons. The contribution for basic ingredient supplies is \$90

**You may only select ONE from Multi Materials (10TEM), Fashion & Design Technology (10FDN) and/or Food Technology (10TEF).**



## FRENCH (10FRE)

### COURSE INFORMATION

Fieldwork:	N/A
Course Contributions:	Workbook \$10 (Highly recommended)
Course Leads to:	Level 1 French
Teacher in charge of subject:	Mrs Killip
HOLA in charge of subject:	Mrs Killip

Year 10 French develops all 4 language skills of listening, reading, writing and speaking to enable students to communicate and cope in a real-life situation. Students will be able to engage with new ways of thinking, questioning and interpreting their world using a wide range of resources (games, technology) which will make the lessons fun and interactive. The aim is for them to understand how languages work, help them to communicate more effectively in a new language but also in their own language(s). The course will cover theme-based vocabulary and sentence structures with topics that are engaging and current and talk about their routine, at home and at school, talking also about their favourite activities and their future plans. Students will also become familiar with NCEA style assessments and will be given the opportunity to use their language skills with native speakers.

This course is designed for second language learners and builds on skills developed in Year 9. However, students who did not take French in Year 9 are also welcome to join. The course begins with revision and consolidation of key content to support those who are new to the language. It is aligned with Level 1 NCEA achievement standards, which are intended for students who are acquiring skill in French. The content is accessible to those who began formal study of the language in junior secondary school.

**NOTE:** If you are a heritage speaker of French (for example, you speak French at home but have had little or no formal education in the language), you must email the Teacher in Charge to arrange a time to assess your language level before choosing this course.



# YEAR 10 OPTIONAL SUBJECTS (choose 3 options)

## INVESTIGATIVE GEOGRAPHY (10IGO)

### COURSE INFORMATION

Fieldwork:	Field trips: A one day trip into Auckland City, local field work and a two day field trip to Waitomo. Other opportunities may arise.
Course Contributions:	\$30 for transport for the Auckland field trip (estimated). \$225 for the two day Waitomo field trip (estimated).
Course Leads to:	Level 1 Geography
Teacher in charge of subject:	Miss Brodie
HOLA in charge of subject:	Miss Douglas



Location, location, location. Why is location so important? What are the factors that affect where urban areas are situated? Mega cities: why are they so large? What is it like to live in them? Are cities sustainable? We will also look at factors affecting the liveability of Auckland and the geography of business locations.

The geography of disease is investigated. What factors assist the spread of diseases today and in the past; spatial epidemiology and its contribution to containing disease outbreaks. Where are contagious and non-communicable diseases prevalent today and why? What are the consequences of these diseases for people and their families?

Adventure landscapes and fizzy rock looks at the formation of limestone landscapes, how they have been used in the past by people and how they are used by people today.



Field work and practical work are important in this course, involving team work and navigation in our urban environment with an introduction to using GPS and GIS technology. A two day field trip to Waitomo is planned.

This course is designed to get students thinking about the world we live in, how some of the natural and cultural features in it are formed and how we interact with them. In the process, students learn a number of geographic skills. It is an academic course with a practical component. A positive and enthusiastic attitude is required.

## JAPANESE (10JAP)

### COURSE INFORMATION

Fieldwork:	Opportunity to take part in the national Japanese Trivia Night.
Course Contributions:	\$10 Workbook (highly recommended)
Course Leads to:	Level 1 Japanese
Teacher in charge of subject:	Ms Lodge
HOLA in charge of subject:	Ms Lodge

Students learn to talk about themselves and others, school life, daily routines, and travel. They build confidence in using a greater range of verbs and sentence patterns to give and understand information, ask questions, and take part in everyday conversations.

By the end of the year, students will be able to interact more naturally in Japanese, read and write short texts, and understand more about Japanese culture and customs. This course helps develop communication skills and cultural understanding through real-life language use.

This course is designed for second language learners and builds on skills developed in Year 9. However, students who did not take Japanese in Year 9 are also welcome to join. The course begins with revision and consolidation of key content to support those who are new to the language. It is aligned with Level 1 NCEA achievement standards, which are intended for students who are acquiring skill in Japanese. The content is accessible to those who began formal study of the language in junior secondary school.

NOTE: If you are a heritage speaker of Japanese (for example, you speak Japanese at home but have had little or no formal education in the language), you must email the Teacher in Charge to arrange a time to assess your language level before choosing this course.



# YEAR 10 OPTIONAL SUBJECTS (choose 3 options)

## TE REO MĀORI (10MAO)

### COURSE INFORMATION

Fieldwork:	Bone Carving Workshops, Polyfest, Māori events
Course Contributions:	N/A
Course Leads to:	Level 1 Te Reo Māori
Teacher in charge of subject:	Whaea Roimata
HOLA in charge of subject:	Ms Lodge

**“Poipoia te kākāno kia puāwaitia”**

**Nurture the seed so that it may blossom**

*This whakatauki has been carefully selected to indicate the importance of fostering identity via te reo Māori.*

Tikanga Māori sits at the heart of our classes. This encourages students to develop a deeper understanding and appreciation of te ao Māori (the Māori world). As language and culture are inextricably linked, students will be explicitly exposed to tikanga (customary practices and values) alongside their learning of te reo. Within the course, students will communicate about their whānau relationships, learn waiata and local iwi stories, belongings, likes and dislikes, physical characteristics, feelings, and day to day life including themes such as time, weather, and seasons. Te reo Māori provides a platform for future studies at NCEA and tertiary level, and opens doors to highly competitive career pathways.

Nau mai ki te huarahi Māori – We welcome all to this whānau learning space!



## MEDIA STUDIES (10MED)

### COURSE INFORMATION

Fieldwork:	N/A
Course Contributions:	N/A
Course Leads to:	Level 1 Media Studies
Teacher in charge of subject:	Mr Greenstreet
HOLA in charge of subject:	Ms Servanin

Do you love using social media, watching movies, or making videos? Those are all media, and Media Studies is for you! It's perfect for anyone who wants to get better at communication, social media, and filmmaking while also learning to think critically about the world around us. Plus, it's the first step in a 4-year Media Studies program at BDSC, setting you up for awesome opportunities in the future.

In Year 10 Media Studies, you'll dive into the basics that will set you up for senior Media Studies. You'll start to see how media shapes our lives and why it's so important for society.

Throughout the year, you'll do cool stuff like close reading and film analysis, studying film genres, exploring animation and satire, and eventually planning and making your own short film. You'll get hands-on experience with cameras, sound, and editing software. The highlight is in Term 4, where you'll work in small groups to film, produce, and edit a short film of any genre you choose – whether it's a narrative film, music video, or documentary. Get ready to unleash your creativity!



# YEAR 10 OPTIONAL SUBJECTS (choose 3 options)

## MULTI MATERIALS TECHNOLOGY (10TEM)

### COURSE INFORMATION

Fieldwork:	N/A
Course Contributions:	\$50
Course Leads to:	Level 1 Multi Materials
Teacher in charge of subject:	Mr Jowers-Wilding
HOLA in charge of subject:	Mr Achary

This course builds on the skills and knowledge students have gained in Year 9. Students in Year 10 are presented with a range of challenging and authentic projects aimed at developing their technological literacy, increasing their range of workshop skills and expanding their understanding of the different material properties and processes associated with wood, metal and plastic.

Students are encouraged to think creatively, using their problem solving skills to develop successful design solutions and quality outcomes. The course is intended to provide students with a sound background for senior NCEA Technology courses.

*You may only select ONE from Multi Materials (10TEM), Fashion & Design Technology (10FDN) and Food Technology (10TEF).*

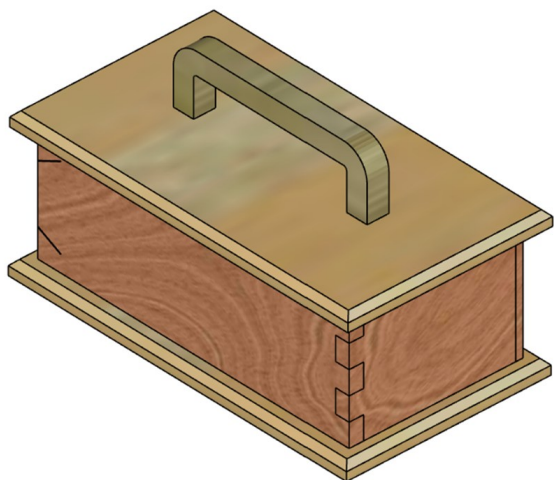

## MUSIC (10MUS)

### COURSE INFORMATION

Fieldwork:	N/A
Course Contributions:	\$23 (Trip to orchestra/opera) estimated
Course Leads to:	Level 1 Music
Teacher in charge of subject:	Ms Treneman
HOLA in charge of subject:	Ms Treneman

The Year 10 Music course allows students' to develop their aural, performing, composition and music appreciation skills. The course is taught around a theme which runs throughout the year and provides a context for the learning and the assessments. Assessment tasks will involve a range of activities including composing music, using computer music notation and recording programs, and performing solo and as part of a small group. It is **essential** that students taking this course learn an instrument, either privately or through the itinerant music programme in school.



# YEAR 10 OPTIONAL SUBJECTS (choose 3 options)

## OUTDOOR EDUCATION (10OED)

### COURSE INFORMATION

Fieldwork:	2xTramping, Rock climbing, Mountain biking, Archery, Crafting and Kayaking
Course Contributions:	Approx. \$500 based on 2026
Course Leads to:	Level 1 Outdoor Education, Level 1 Physical Education
Uniform	For practical lessons, students must have the BDSC 'Sport' T-shirt and BDSC
Teacher in charge of subject:	Ms Patel
HOLA in charge of subject:	Mr Saville

Outdoor Education (10OED) helps students develop personal and social skills, build confidence in the outdoors, and foster environmental responsibility. Activities may include rock climbing, archery, tramping, mountain biking, and bushcraft.

The course blends outdoor experiences with class-based learning focused on leadership, katiakitanga and teamwork. Students will learn to lead and teach others in areas such as bushcraft and team-building. Some trips and assessments take place outside school hours—dates will be confirmed early in the year. Students are expected to catch up on any missed classwork.

This is an introduction to senior Outdoor Education, with opportunities to earn Level 1 Unit Standard credits. The course can be physically and mentally demanding, so regular fitness tests will be held before trips.

Important: Year 10 Outdoor Education will run in 2027, limited to two classes only. Students must select 10OED in the web portal and submit a signed, dated application to Ms Patel (Head of OED) by the Option Selection deadline. Applications must briefly explain why they want to take the course and understand that being able to swim, ride a bike, and stay at camps overnight is a prerequisite. Final selection will be made in consultation with HPE staff. Students taking OED will need as a minimum to have a waterproof jacket, fleece top and bottoms, thermal top and bottoms and appropriate footwear for tramps.

**Note: you cannot take both Outdoor Education (10OED) and Physical Education (10PED).**



## PHYSICAL EDUCATION (10PED)

### COURSE INFORMATION

Fieldwork:	N/A
Uniform:	Whanau PE shirts or BDSC 'Sports' T-shirt with BDSC PE Shorts
Course Leads to:	Level 1 Physical Education, Level 1 Outdoor Education
Teacher in charge of subject:	Mr Hough
HOLA in charge of subject:	Mr Saville

Year 10 Physical Education option (10PED) was set up to support students wanting to study Physical Education at NCEA to optimise their academic learning and achievement at Year 11 and beyond. Learning in 10PED is a more academic and performance-oriented PE course, compared to your learning in 10PEC (core PE).

The course will include learning about the principles and methods of training for enhancing fitness levels (SportFITT), athlete-centred nutrition concepts for enhancing training and performance (Sports Nutrition), strategies for enhancing skill performance such as technique, drills, and feedback (Skill Learning), as well as strategies for enhancing kotahitanga (unity) to improve team performance in sport (Kotahitanga).

Year 10 Physical Education includes a combination of both practical and theory lessons. The amount of practical will vary according to the unit of learning.

Course pre-requisites: Students will have consistently gained Consolidating or above in their Year 9 Application in Physical Education grades.

**Note: you cannot take both Outdoor Education (10OED) and Physical Education (10PED).**

